

PRO-FORM[®]

With Universal Dock for iPod[®]

980 CS

Model No. PFTL99908.0

Serial No. _____

Write the serial number in the space above for reference.

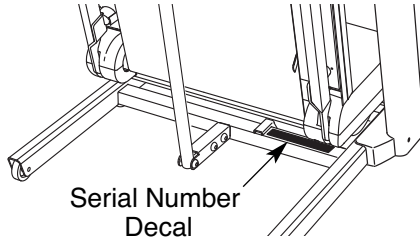

USER'S MANUAL

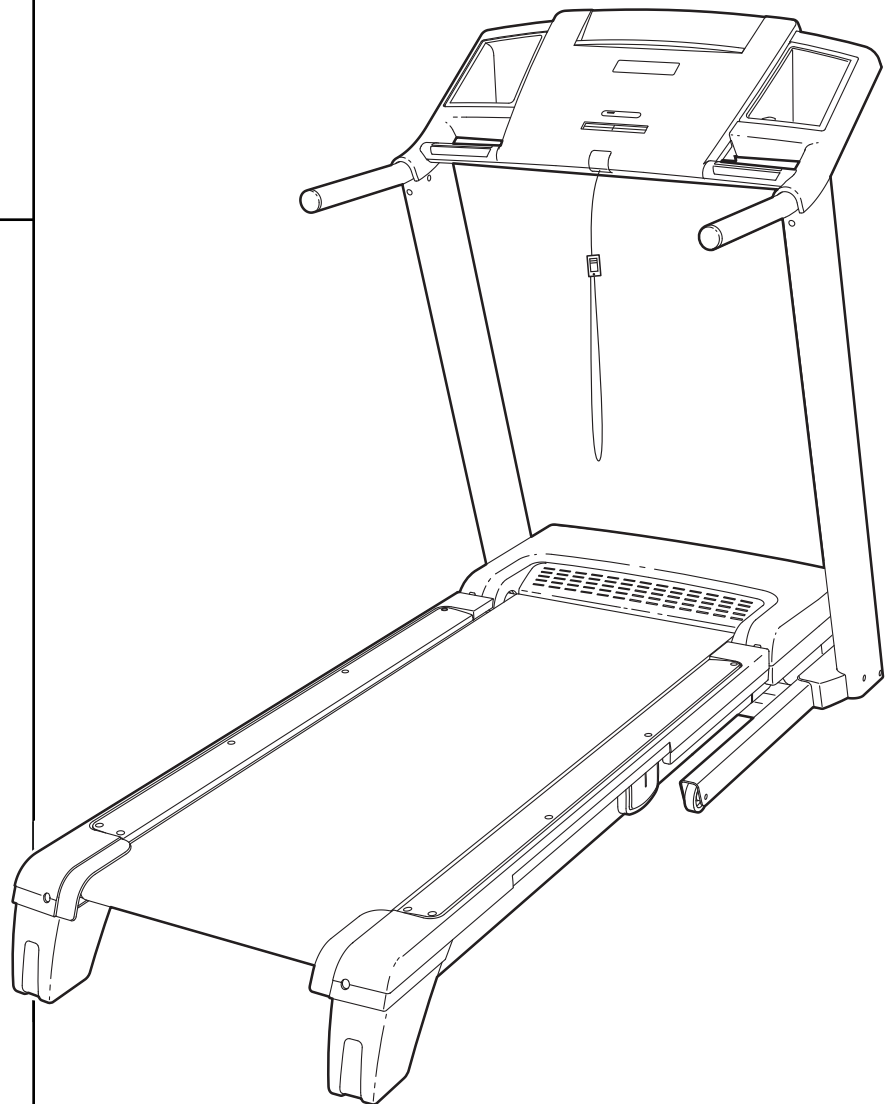

QUESTIONS?

As a manufacturer, we are committed to providing complete customer satisfaction. If you have questions, or if parts are missing, **PLEASE DO NOT CONTACT THE STORE; please contact Customer Care.**

IMPORTANT: You must note the product model number and serial number (see the drawing above) before contacting us:

CALL TOLL-FREE:

1-888-533-1333

Mon.–Fri. 6 a.m.–6 p.m. MST

Sat. 8 a.m.–4 p.m. MST

ON THE WEB:

www.proformservice.com

CAUTION

Read all precautions and instructions in this manual before using this equipment. Save this manual for future reference.



Visit our website at

www.proform.com

new products, prizes,
fitness tips, and much more!

TABLE OF CONTENTS

WARNING DECAL PLACEMENT2
IMPORTANT PRECAUTIONS3
BEFORE YOU BEGIN5
ASSEMBLY6
OPERATION AND ADJUSTMENT12
HOW TO FOLD AND MOVE THE TREADMILL24
TROUBLESHOOTING26
EXERCISE GUIDELINES29
PART LIST30
EXPLODED DRAWING32
ORDERING REPLACEMENT PARTSBack Cover
LIMITED WARRANTYBack Cover

WARNING DECAL PLACEMENT

This drawing shows the locations of the warning decals. **If a decal is missing or illegible, call the telephone number on the front cover of this manual and request a free replacement decal. Apply the decal in the location shown.** Note: The decals may not be shown at actual size.

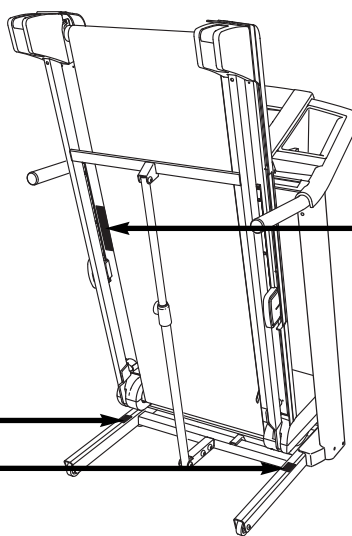



▲WARNING:

Protect yourself and others from risk of serious injury. Read the user's manual and:

-  •Stand only on the side rails when starting or stopping treadmill.
- Change speed in small increments.
- Hold handrails to prevent falling, and always wear the safety clip while operating treadmill.
- Stop if you feel faint, dizzy, or short of breath.
- Fully engage storage latch before treadmill is moved or stored.
- Reduce incline to its lowest level before folding treadmill into storage position.

-  •Never allow children on or around treadmill.
- Remove key when not in use.

-  •Keep clothing, fingers, and hair away from moving belt.
- Never try to adjust or fix the belt while it is moving.

-  •Always wear athletic shoes while operating treadmill.

IMPORTANT PRECAUTIONS

⚠ WARNING: To reduce the risk of serious injury, read all important precautions and instructions in this manual and all warnings on your treadmill before using your treadmill. ICON assumes no responsibility for personal injury or property damage sustained by or through the use of this product.

1. Before beginning any exercise program, consult your physician. This is especially important for persons over the age of 35 or persons with pre-existing health problems.
2. It is the responsibility of the owner to ensure that all users of this treadmill are adequately informed of all warnings and precautions.
3. Use the treadmill only as described.
4. Place the treadmill on a level surface, with at least 8 ft. (2.4 m) of clearance behind it and 2 ft. (0.6 m) on each side. Do not place the treadmill on any surface that blocks air openings. To protect the floor or carpet from damage, place a mat under the treadmill.
5. Keep the treadmill indoors, away from moisture and dust. Do not put the treadmill in a garage or covered patio, or near water.
6. Do not operate the treadmill where aerosol products are used or where oxygen is being administered.
7. Keep children under the age of 12 and pets away from the treadmill at all times.
8. The treadmill should be used only by persons weighing 350 lbs. (159 kg) or less.
9. Never allow more than one person on the treadmill at a time.
10. Wear appropriate exercise clothes when using the treadmill. Do not wear loose clothes that could become caught in the treadmill. Athletic support clothes are recommended for both men and women. *Always wear athletic shoes. Never use the treadmill with bare feet, wearing only stockings, or in sandals.*
11. When connecting the power cord (see page 12), plug the power cord into a surge suppressor (not included) and plug the surge suppressor into a grounded circuit capable of carrying 15 or more amps. No other appliance should be on the same circuit. Do not use an extension cord.
12. Use only a single-outlet surge suppressor that meets all of the specifications described on page 12. To purchase a surge suppressor, see your local PROFORM dealer or call the telephone number on the front cover of this manual and order part number 146148, or see your local electronics store.
13. Failure to use a properly functioning surge suppressor could result in damage to the control system of the treadmill. If the control system is damaged, the walking belt may change speed, accelerate, or stop unexpectedly, which may result in a fall and serious injury.
14. Keep the power cord and the surge suppressor away from heated surfaces.
15. Never move the walking belt while the power is turned off. Do not operate the treadmill if the power cord or plug is damaged, or if the treadmill is not working properly. (See TROUBLESHOOTING on page 26 if the treadmill is not working properly.)
16. Read, understand, and test the emergency stop procedure before using the treadmill (see HOW TO TURN ON THE POWER on page 14).
17. Never start the treadmill while you are standing on the walking belt. Always hold the handrails while using the treadmill.
18. The treadmill is capable of high speeds. Adjust the speed in small increments to avoid sudden jumps in speed.
19. The pulse sensor is not a medical device. Various factors, including the user's movement, may affect the accuracy of heart rate readings. The pulse sensor is intended only as an exercise aid in determining heart rate trends in general.

20. Never leave the treadmill unattended while it is running. Always remove the key, unplug the power cord, and switch the reset/off circuit breaker to the off position when the treadmill is not in use. (See the drawing on page 5 for the location of the circuit breaker.)
21. Do not attempt to raise, lower, or move the treadmill until it is properly assembled. (See ASSEMBLY on page 6, and HOW TO FOLD AND MOVE THE TREADMILL on page 24.) You must be able to safely lift 45 lbs. (20 kg) to raise, lower, or move the treadmill.
22. When folding or moving the treadmill, make sure that the storage latch is fully closed.
23. Never insert any object into any opening on the treadmill.
24. Inspect and properly tighten all parts of the treadmill regularly.
25. **DANGER:** Always unplug the power cord immediately after use, before cleaning the treadmill, and before performing the maintenance and adjustment procedures described in this manual. Never remove the motor hood unless instructed to do so by an authorized service representative. Servicing other than the procedures in this manual should be performed by an authorized service representative only.
26. This treadmill is intended for in-home use only. Do not use this treadmill in a commercial, rental, or institutional setting.

SAVE THESE INSTRUCTIONS

BEFORE YOU BEGIN

Thank you for selecting the revolutionary PROFORM® 980 CS treadmill with Universal Dock for iPod®. The 980 CS treadmill with Universal Dock for iPod offers an impressive selection of features designed to make your workouts at home more enjoyable and effective. And when you're not exercising, the unique treadmill can be folded up, requiring less than half the floor space of other treadmills.

For your benefit, read this manual carefully before using the treadmill. If you have questions after reading this manual, please see the front cover of this man-

ual. To help us assist you, note the product model number and serial number before contacting us. The model number and the location of the serial number decal are shown on the front cover of this manual.

To avoid a registration fee for any service needed under warranty, you must register the treadmill at www.proformservice.com/registration.

Before reading further, please familiarize yourself with the parts that are labeled in the drawing below.

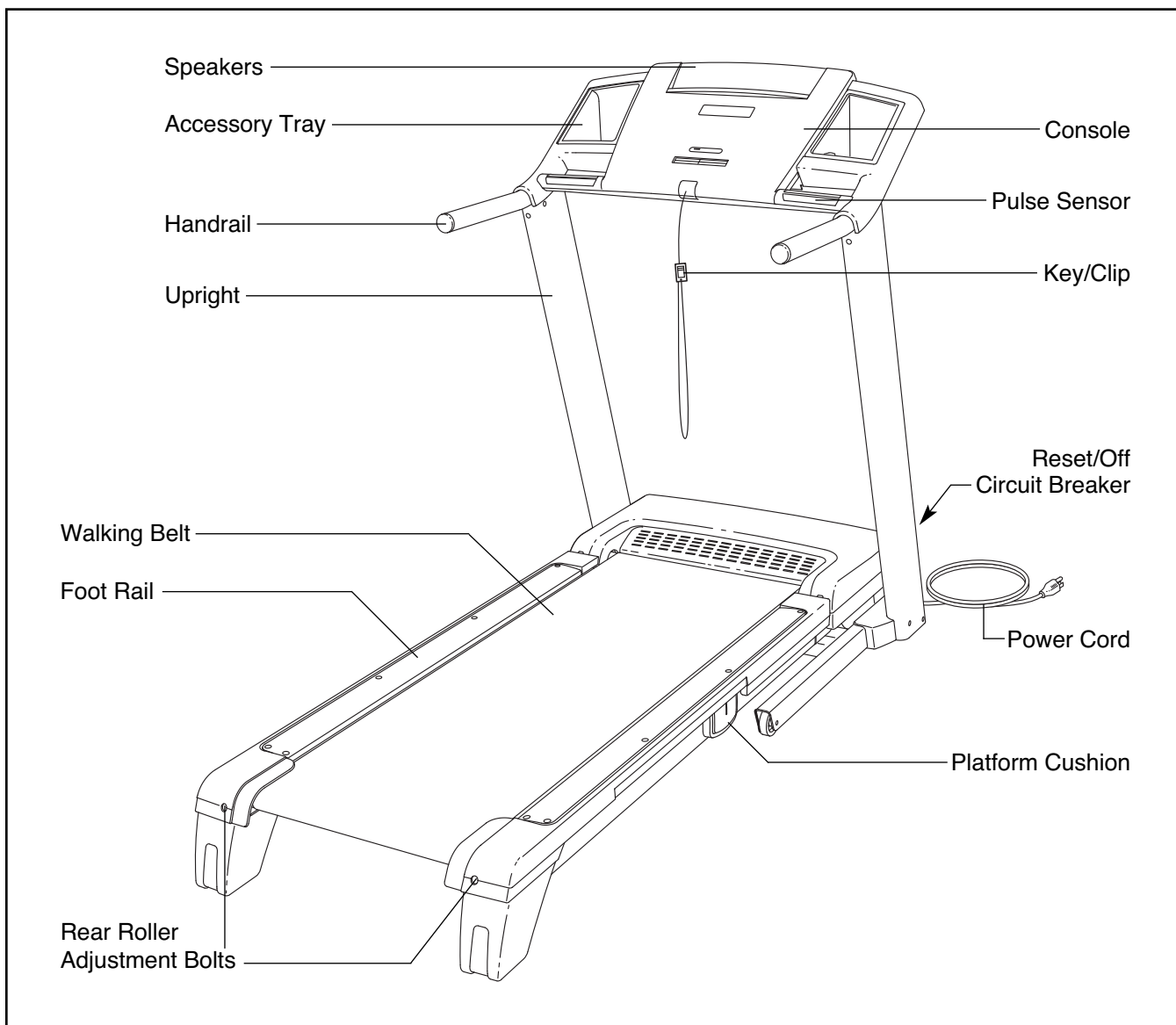

ASSEMBLY

To hire an authorized service technician to assemble the treadmill, call 1-800-445-2480.

Assembly requires two persons. Set the treadmill in a cleared area and remove all packing materials. **Do not dispose of the packing materials until assembly is completed.** Note: The underside of the treadmill walking belt is coated with high-performance lubricant. During shipping, a small amount of lubricant may be transferred to the top of the walking belt or the shipping carton. This is a normal condition and does not affect treadmill performance. If there is lubricant on top of the walking belt, simply wipe off the lubricant with a soft cloth and a mild, non-abrasive cleaner.

Assembly requires the included hex keys  and your own Phillips screwdriver , adjustable wrench , needlenose pliers , and rubber mallet .

Use the drawings below to identify the assembly hardware. The number in parentheses below each drawing is the key number of the part, from the PART LIST near the end of this manual. The number after the parentheses is the quantity needed for assembly. **Note: If a part is not in the hardware kit, check to see if it is preattached to one of the parts to be assembled. To avoid damaging plastic parts, do not use power tools for assembly. Extra hardware may be included.**

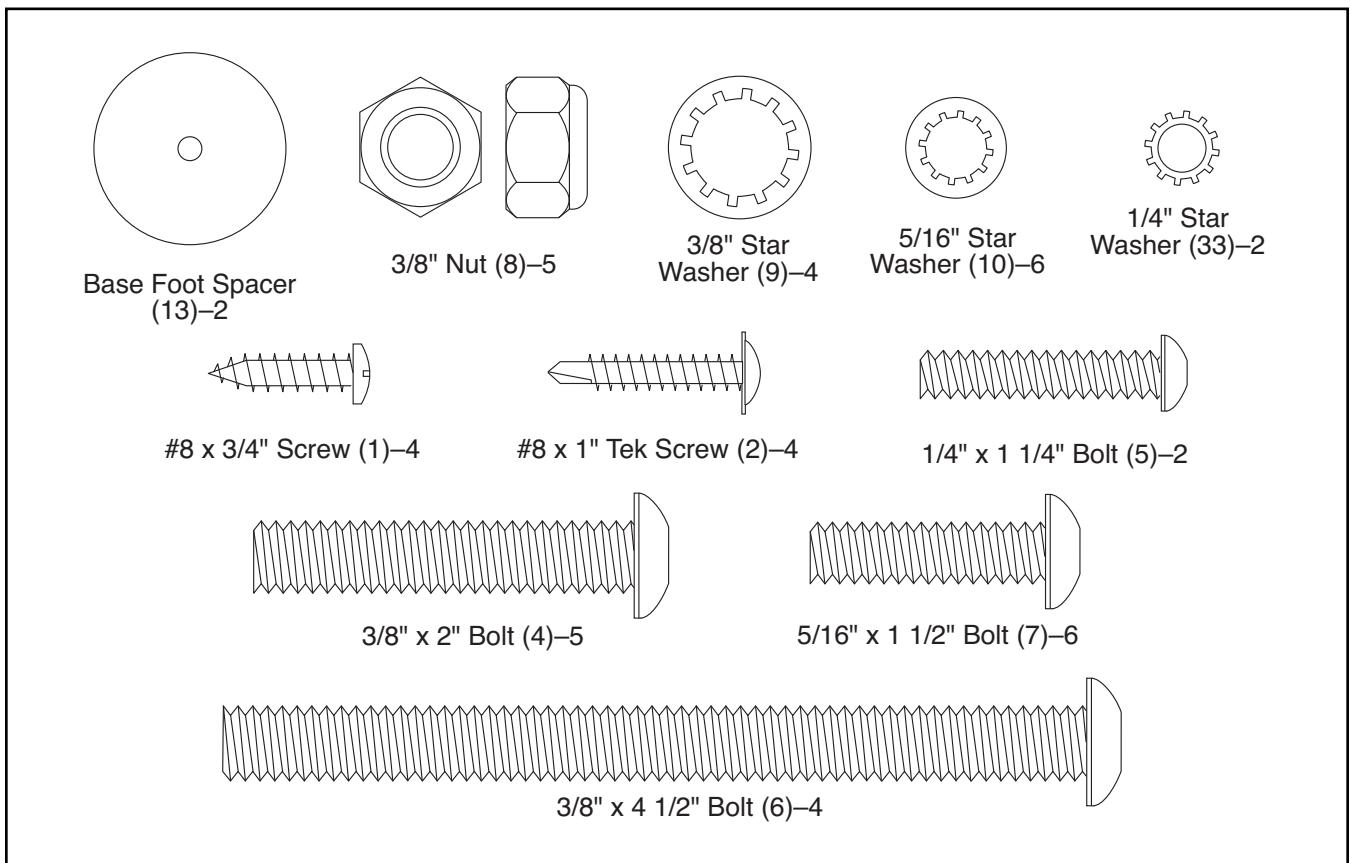

1. **Make sure that the power cord is unplugged.**

With the help of a second person, carefully tip the treadmill onto its left side. Partially fold the Frame (56) so that the treadmill is more stable; **do not fully fold the Frame yet.**

Cut the ties securing the Upright Wire (38) to the Base (83). Locate the tie in the indicated hole in the Base, and use the tie to pull the Upright Wire out of the hole.

Attach a Base Foot (81) to the Base (83) in the location shown with a Base Foot Spacer (13) and a #8 x 1" Tek Screw (2). Then, attach another Base Foot (81) with only a #8 x 1" Tek Screw (2).

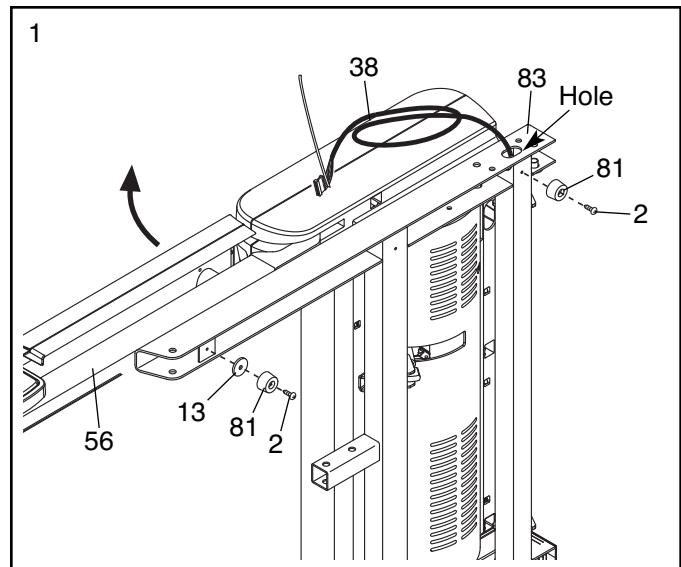

2. Attach a Wheel (84) to the Base (83) with a 3/8" x 2" Bolt (4) and a 3/8" Nut (8). **Do not over-tighten the Nut; the Wheel must turn freely.**

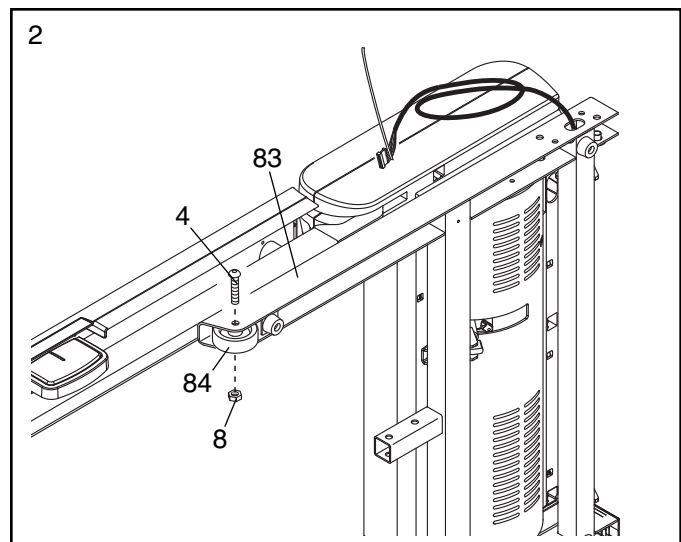

3. Identify the Right Upright (78) and the Right Upright Spacer (79), which are marked with stickers.

Insert the Upright Wire (38) through the Right Upright Spacer (79) as shown. Then, set the Right Upright Spacer (79) on the Base (83). **Be careful not to pinch the Upright Wire.**

Have a second person hold the Right Upright (78) near the Base (83). **See the inset drawing.** Tie the long tie in the Right Upright securely around the end of the Upright Wire (38). Then, pull the other end of the long tie until the Upright Wire is routed completely through the Right Upright.

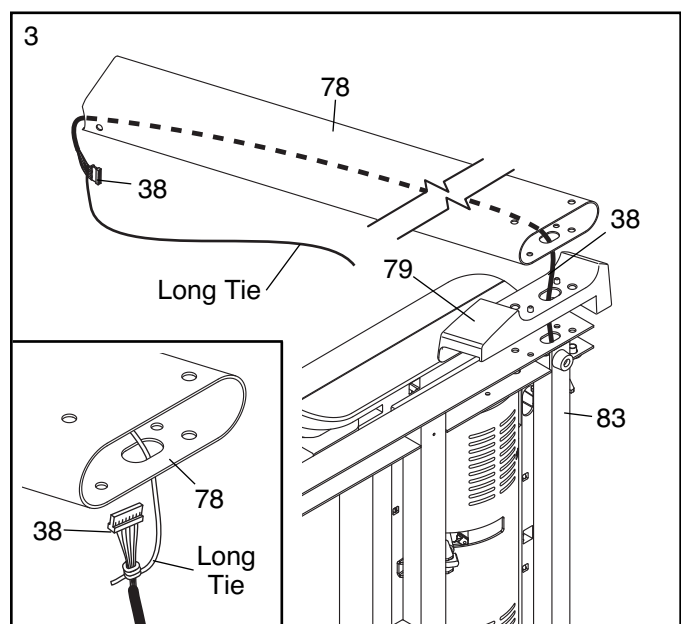

- With the help of a second person, hold a Bolt Spacer (77) inside the lower end of the Right Upright (78). Next, insert a 3/8" x 4 1/2" Bolt (6) with a 3/8" Star Washer (9) into the Right Upright and the Bolt Spacer. **Repeat this step with a second Bolt Spacer (77), 3/8" x 4 1/2" Bolt (6), and 3/8" Star Washer (9).** Then, set the Right Upright in the Right Upright Spacer (79). **Be careful not to pinch the Upright Wire (38).**

Tighten the 3/8" x 4 1/2" Bolts (6) with your fingers; **do not fully tighten the Bolts yet.**

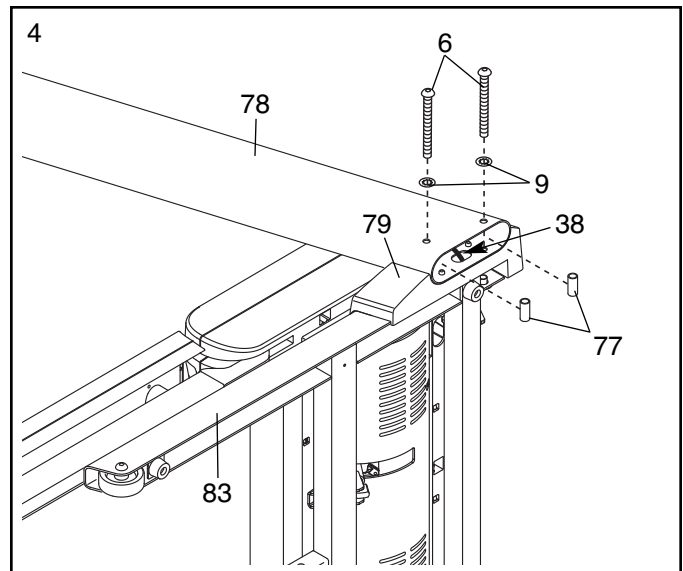

- With the help of a second person, carefully tip the treadmill onto its right side. Partially fold the Frame (56) so the treadmill is more stable; **do not fully fold the Frame yet.**

Attach a Base Foot (81) to the Base (83) in the location shown with a #8 x 1" Tek Screw (2) and a Base Foot Spacer (13). Then, attach another Base Foot (81) with only a #8 x 1" Tek Screw (2).

Attach a Wheel (84) to the Base (83) with a 3/8" x 2" Bolt (4) and a 3/8" Nut (8). **Do not over-tighten the Nut; the Wheel must turn freely.**

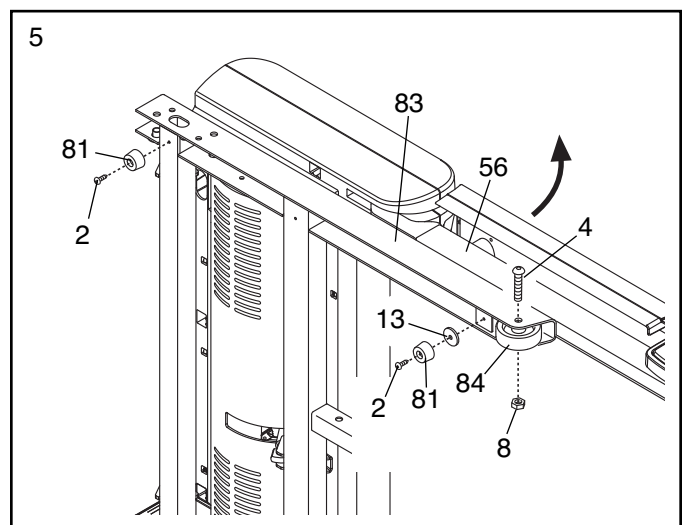

- Set the Left Upright Spacer (76) on the Base (83). With the help of a second person, hold a Bolt Spacer (77) inside the lower end of the Left Upright (74). Next, insert a 3/8" x 4 1/2" Bolt (6) with a 3/8" Star Washer (9) into the Left Upright and the Bolt Spacer. **Repeat this step with a second Bolt Spacer (77), 3/8" x 4 1/2" Bolt (6), and 3/8" Star Washer (9).** Then, set the Left Upright in the Left Upright Spacer.

Tighten the 3/8" x 4 1/2" Bolts (6) with your fingers; **do not fully tighten the Bolts yet.**

With the help of a second person, tip the treadmill so that the Base (83) is flat on the floor.

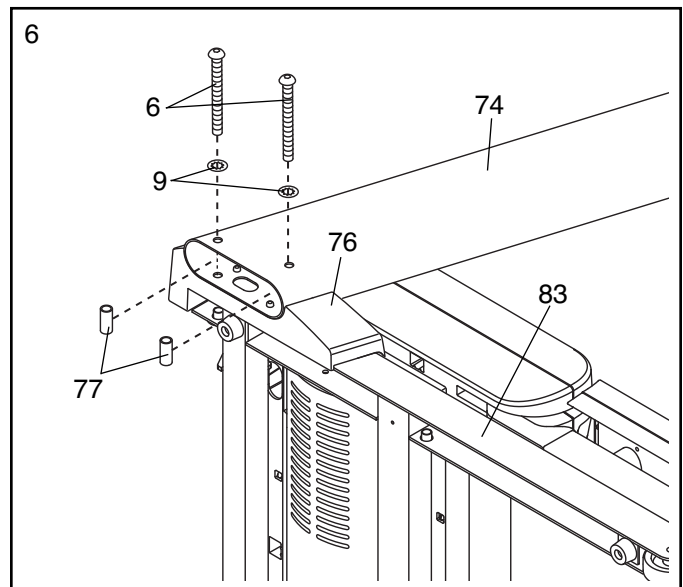

- Set the console assembly face down on a soft surface to avoid scratching the console assembly. Hold the Right Handrail (95) near the console assembly. Next, insert the console wire into the large hole in the Right Handrail and out of the top as shown. If necessary, use needle-nose pliers to pull the console wire out.

Attach the Right Handrail (95) and the Left Handrail (not shown) with four #8 x 3/4" Screws (1) (only two are shown). **Make sure that no wires are pinched. Start all four Screws before tightening any of them; do not over-tighten the Screws.**

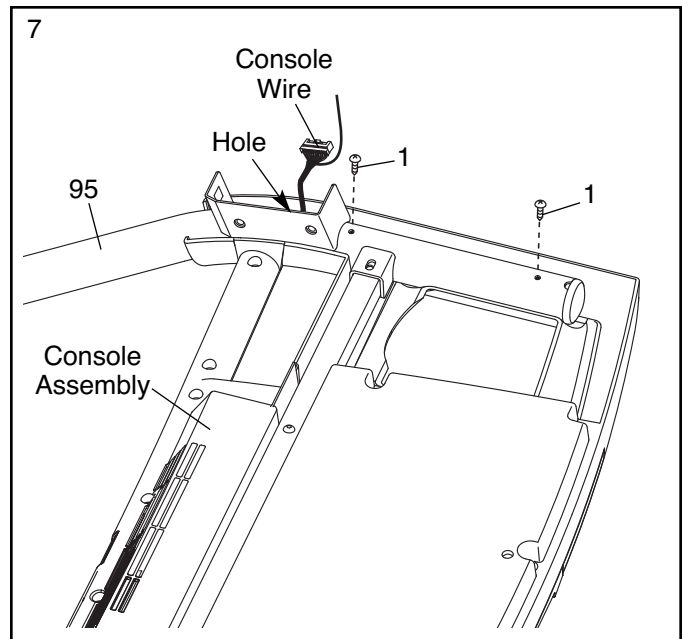

- Tighten a 1/4" x 1 1/4" Bolt (5) with a 1/4" Star Washer (33) into the Handrail Crossbar (94) and the bracket on each side of the console assembly (only one side is shown).

Remove the wire tie from the console wire.

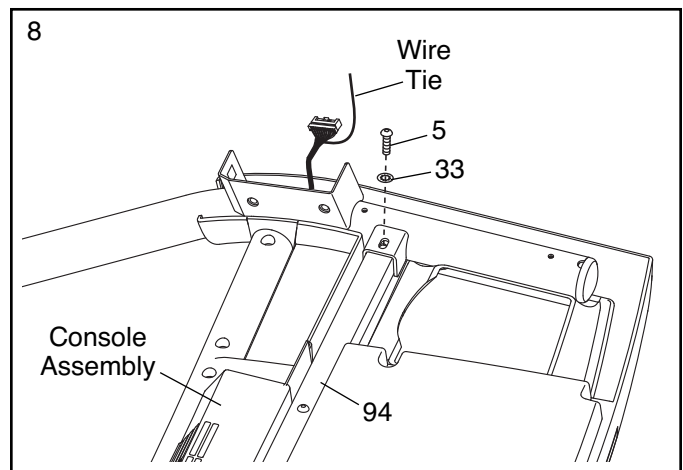

- Remove the tie from the Cage Nut (88).

Have a second person hold the console assembly near the Right Upright (78) and the Left Upright (not shown). Connect the Upright Wire (38) to the console wire. **See the inset drawing. The connectors should slide together easily and snap into place.** If they do not, turn one connector and try again. **IF THE CONNECTORS ARE NOT CONNECTED PROPERLY, THE CONSOLE MAY BE DAMAGED WHEN THE POWER IS TURNED ON.** Then, remove the long tie from the Upright Wire.

Set the console assembly on the Right Upright (78) and the Left Upright (not shown). **Be careful not to pinch the wires.**

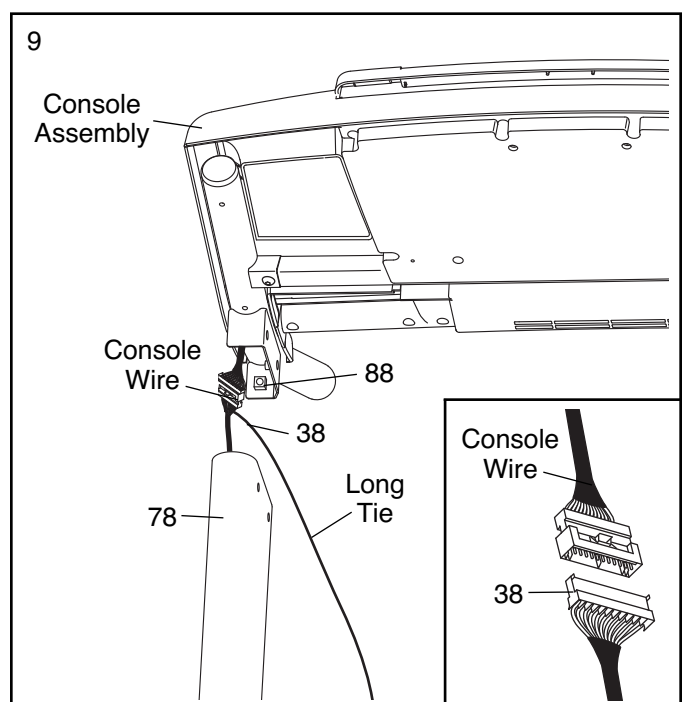

10. Attach the console assembly with six 5/16" x 1 1/2" Bolts (7) and six 5/16" Star Washers (10) (only three are shown).

See steps 4 and 6. Tighten the 3/8" x 4 1/2" Bolts (6).

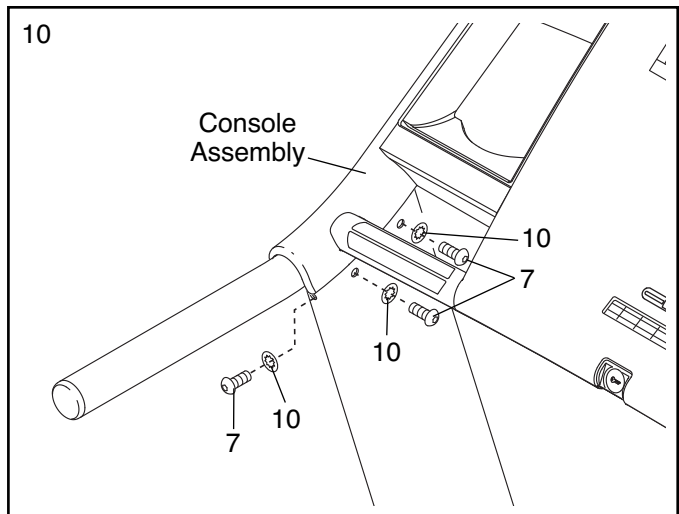

11. Raise the Frame (56) to the position shown. **Have a second person hold the Frame until this step is completed.**

Orient the Storage Latch (53) so that the large barrel and the Latch Knob (54) are in the positions shown.

Attach the Latch Bracket (14) and the Storage Latch (53) to the Base (83) with two 3/8" x 2" Bolts (4) and two 3/8" Nuts (8).

Attach the upper end of the Storage Latch (53) to the bracket on the Frame (56) with a 3/8" x 2" Bolt (4) and a 3/8" Nut (8). Note: It may be necessary to move the Frame back and forth to align the Storage Latch with the bracket.

Lower the Frame (56) (see HOW TO LOWER THE TREADMILL FOR USE on page 25).

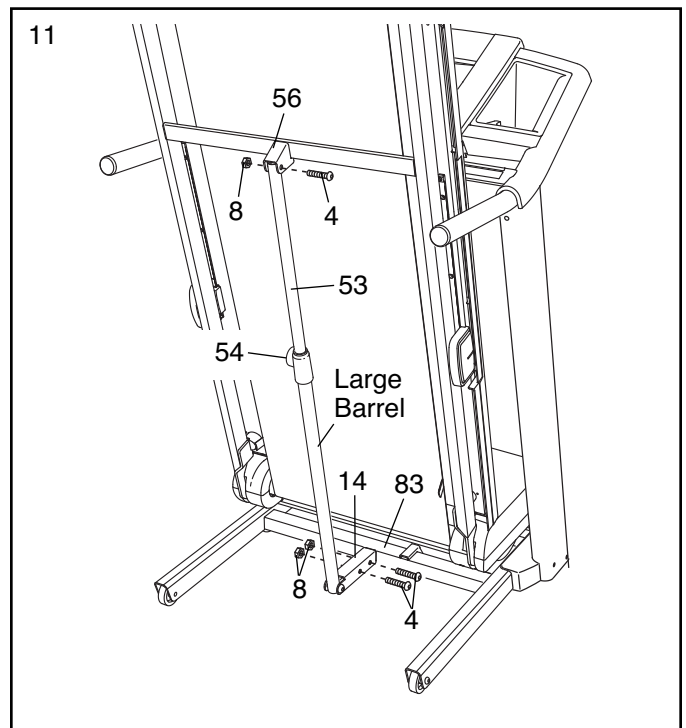

12. Press the Left Accessory Tray (99) and the Right Accessory Tray (106) into the Console Base (91).

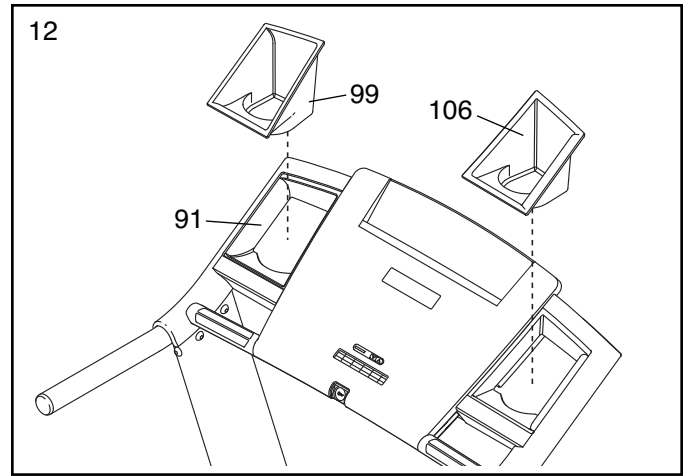

13. **Make sure that all parts are properly tightened before you use the treadmill.** If there are sheets of clear plastic on the treadmill decals, remove the plastic. To protect the floor or carpet, place a mat under the treadmill. Note: Extra hardware may be included. Keep the included hex keys in a secure place; one of the hex keys is used to adjust the walking belt (see pages 27 and 28).

If you purchase the optional chest pulse sensor (see page 23), follow the steps below to install the receiver included with the chest pulse sensor.

1. **Make sure that the power cord is unplugged.** Remove the indicated #8 x 3/4" Screw (1) and the Access Door (87) from the Console Base (91).
2. Connect the wire on the receiver to the indicated wire extending from the Console Base (91). **Hold the receiver so that the antenna is oriented as shown and is facing the Console Base.** Attach the receiver to the plastic posts on the Access Door (87) with the two included small screws.
3. **Make sure that no wires are pinched.** Reattach the Access Door (87) with the #8 x 3/4" Screw (1). Discard the other wires included with the receiver.

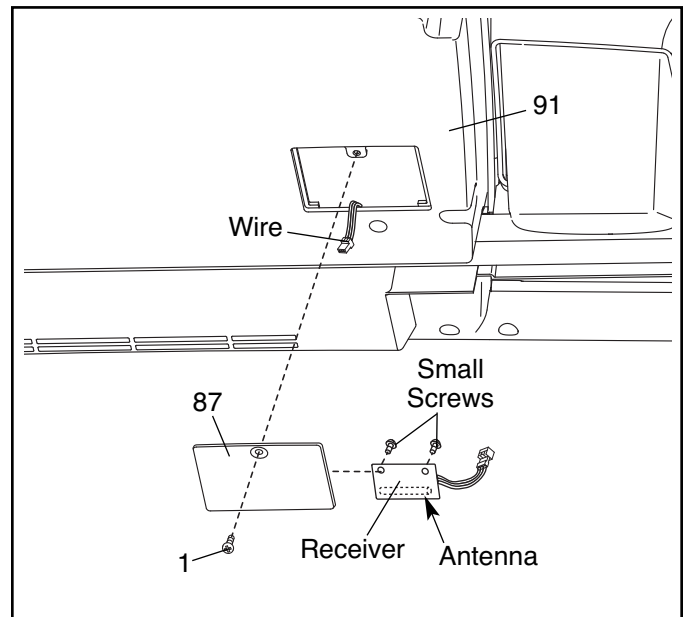

OPERATION AND ADJUSTMENT

THE PRE-LUBRICATED WALKING BELT

Your treadmill features a walking belt coated with high-performance lubricant. **IMPORTANT: Never apply silicone spray or other substances to the walking belt or the walking platform. Such substances will deteriorate the walking belt and cause excessive wear.**

HOW TO PLUG IN THE POWER CORD

⚠ DANGER: Improper connection of the equipment-grounding conductor can result in an increased risk of electric shock. Check with a qualified electrician or serviceman if you are in doubt as to whether the product is properly grounded. Do not modify the plug provided with the product—if it will not fit the outlet, have a proper outlet installed by a qualified electrician.

Your treadmill, like any other type of sophisticated electronic equipment, can be seriously damaged by sudden voltage changes in your home's power. Voltage surges, spikes, and noise interference can result from weather conditions or from other appliances being turned on or off. **To decrease the possibility of your treadmill being damaged, always use a surge suppressor with your treadmill (see drawing 1 at the right).** To purchase a surge suppressor, see your local PROFORM dealer or call the telephone number on the front cover of this manual and order part number 146148, or see your local electronics store.

Use only a single-outlet surge suppressor that is UL 1449 listed as a transient voltage surge suppressor (TVSS). The surge suppressor must have a UL suppressed voltage rating of 400 volts or less and a minimum surge dissipation of 450 joules. The surge suppressor must be electrically rated for 120 volts AC and 15 amps. There must be a monitoring light on the surge suppressor to indicate whether it is functioning properly. Failure to use a properly functioning surge suppressor could result in damage to the control system of the treadmill. If the control system is damaged, the walking belt may change speed, accelerate, or stop unexpectedly, which may result in a fall and serious injury.

This product must be grounded. If it should malfunction or break down, grounding provides a path of least resistance for electric current to reduce the risk of elec-

tric shock. This product is equipped with a cord having an equipment-grounding conductor and a grounding plug. **Plug the power cord into a surge suppressor, and plug the surge suppressor into an appropriate outlet that is properly installed and grounded in accordance with all local codes and ordinances. IMPORTANT: The treadmill is not compatible with GFCI-equipped outlets.**

This product is for use on a nominal 120-volt circuit, and has a grounding plug that looks like the plug illustrated in drawing 1 below. A temporary adapter that looks like the adapter illustrated in drawing 2 may be used to connect the surge suppressor to a 2-pole receptacle as shown in drawing 2 if a properly grounded outlet is not available.

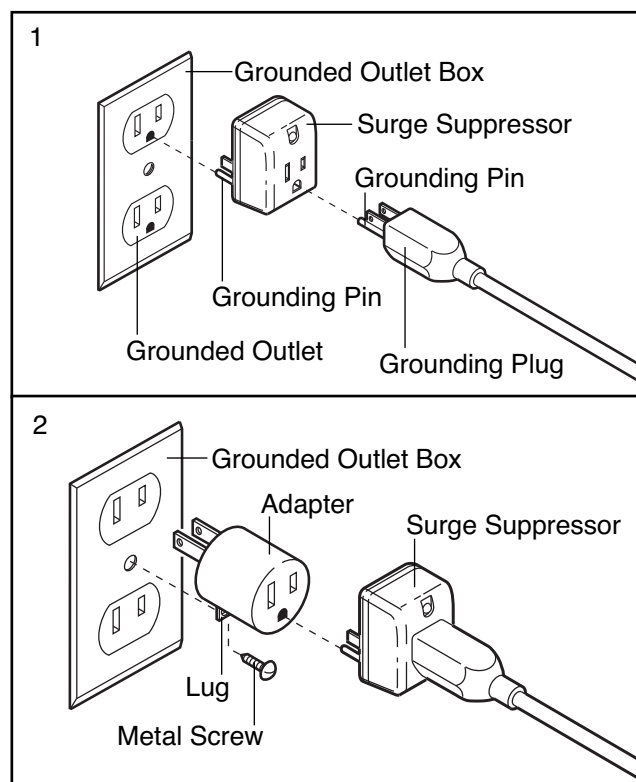

The temporary adapter should be used only until a properly grounded outlet (drawing 1) can be installed by a qualified electrician.

The green-colored rigid ear, lug, or the like extending from the adapter must be connected to a permanent ground such as a properly grounded outlet box cover. Whenever the adapter is used it must be held in place by a metal screw. **Some 2-pole receptacle outlet box covers are not grounded. Contact a qualified electrician to determine if the outlet box cover is grounded before using an adapter.**

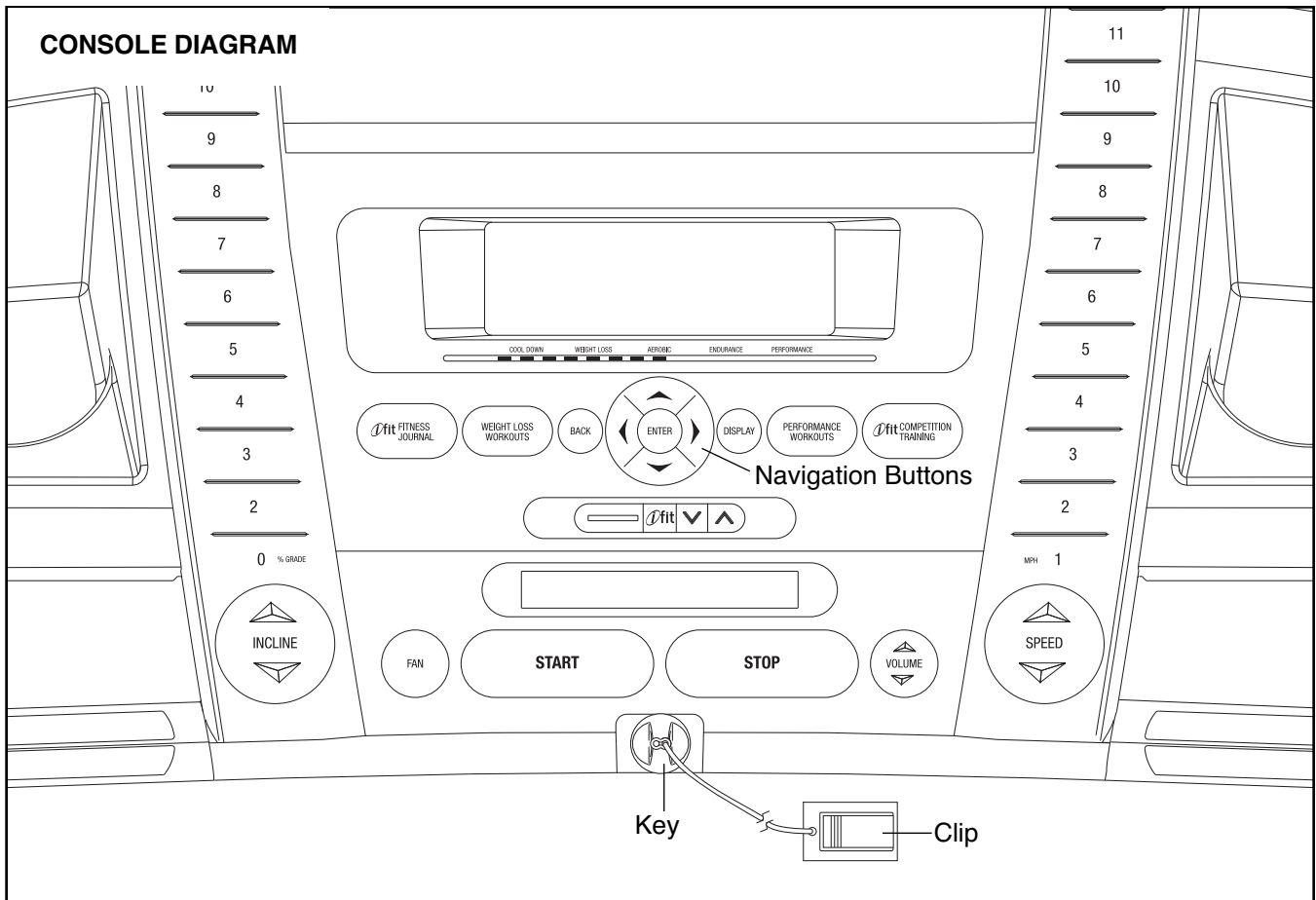

FEATURES OF THE CONSOLE

The revolutionary treadmill console offers a selection of features designed to make your workouts more effective and enjoyable. When you use the manual mode of the console, you can change the speed and incline of the treadmill with the touch of a button. As you exercise, the console will display continuous exercise feedback. You can even measure your heart rate using the handgrip pulse sensor or the optional chest pulse sensor (see page 23 for more information on the optional chest pulse sensor).

In addition, the console features sixteen preset workouts—eight weight loss workouts and eight performance workouts. Each workout automatically controls the speed and incline of the treadmill as it guides you through an effective workout. You can even compete against animated runners using the iFit Competition Training workout.

The console features an iFit Fitness Journal, which automatically records and stores your exercise information so that you can view your workout history and track your progress.

The console also features the new iFit Interactive Workout system. The iFit system enables the console

to accept iFit Interactive Workout Cards containing workouts designed to help you achieve specific fitness goals. For example, lose unwanted pounds with the 8-week Weight Loss workout, or train for a long-distance run with the Marathon workout. iFit workouts automatically control the treadmill while the voice of a personal trainer coaches you and motivates you through every step of your workout. **To purchase iFit cards at any time, call the telephone number on the front cover of this manual.**

You can even listen to your favorite workout music or audio books with the console's premium stereo sound system while you get in shape. This product has been designed specifically to work with iPod and has been certified by the developer to meet Apple performance standards.

To turn on the power, see page 14. To use the manual mode, see page 14. To use a weight loss workout or a performance workout, see page 16. To use an iFit card, see page 17. To use the iFit Competition Training workout, see page 18. To personalize console settings, see page 20. To view the fitness journal, see page 21. To use the information mode, see page 22. To use the stereo sound system, see page 22.

HOW TO TURN ON THE POWER

IMPORTANT: If the treadmill has been exposed to cold temperatures, allow it to warm to room temperature before turning on the power. If you do not do this, the console displays or other electrical components may become damaged.

Plug in the power cord (see page 12). Next, locate the reset/off circuit breaker on the treadmill frame near the power cord. Switch the circuit breaker to the reset position.

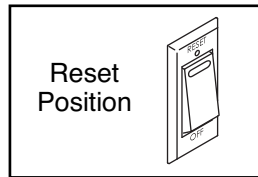

IMPORTANT: The console features a display demo mode, designed to be used if the treadmill is displayed in a store. If the displays light as soon as you plug in the power cord and switch the circuit breaker to the reset position, the demo mode is turned on. To turn off the demo mode, hold down the Stop button for a few seconds. If the displays remain lit, see THE INFORMATION MODE on page 22 to turn off the demo mode.

Next, stand on the foot rails of the treadmill. Find the clip attached to the key (see the drawing on page 13) and slide the clip onto the waistband of your clothes. Then, insert the key into the console. After a moment, the displays will light. **IMPORTANT:** In an emergency situation, the key can be pulled from the console, causing the walking belt to slow to a stop. Test the clip by carefully taking a few steps backward; if the key is not pulled from the console, adjust the position of the clip.

Note: If there is a sheet of clear plastic on the face of the console, remove the plastic. To prevent damage to the walking platform, wear clean athletic shoes while using the treadmill. The first time you use the treadmill, observe the alignment of the walking belt, and center the walking belt if necessary (see page 28).

Note: The console can display speed and distance in either miles or kilometers. To find out which unit of measurement is selected or to change the unit of measurement, see THE INFORMATION MODE on page 22. For simplicity, all instructions in this section refer to miles.

HOW TO USE THE MANUAL MODE

1. Insert the key into the console.

See HOW TO TURN ON THE POWER at the left.

2. Personalize console settings if desired.

See HOW TO PERSONALIZE CONSOLE SETTINGS on page 20.

3. Select the manual mode.

Each time you insert the key, the manual mode will be selected. If you have selected a workout, press any of the workout buttons repeatedly until only zeros appear in the display.

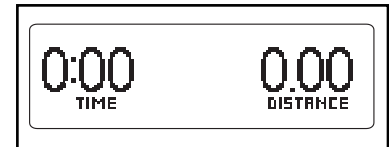

4. Start the walking belt and adjust the speed.

To start the walking belt, press the Start button, the Speed increase button, or one of the speed buttons number 1 to 12. Note: After you press the buttons, it may take a moment for the walking belt to reach the selected speed setting.

If you press the Start button or the Speed increase button, the walking belt will begin to move at 1 mph. As you exercise, change the speed of the walking belt as desired by pressing the Speed increase and decrease buttons. Each time you press a button, the speed setting will change by 0.1 mph; if you hold down a button, the speed setting will change in increments of 0.5 mph. If you press one of the twelve numbered speed buttons, the speed of the walking belt will gradually adjust until it reaches the selected speed setting.

To stop the walking belt, press the Stop button. To restart the walking belt, press the Start button, the Speed increase button, or one of the numbered speed buttons.

5. Change the incline of the treadmill as desired.

To change the incline of the treadmill, press the Incline increase or decrease buttons, or one of the incline buttons numbered 0 to 12. Each time you press a button, the incline will gradually adjust until it reaches the selected incline setting.

6. Follow your progress with the display.

The console offers several display options. The display option you select will determine which workout information is shown. Press the Display button repeatedly to select the desired display option.

As you walk or run on the treadmill, the display can show the following workout information:

- The elapsed time.
- The distance that you have walked or run.
- The approximate number of calories you have burned.
- The speed of the walking belt.
- The incline level of the treadmill.
- Your pace in minutes per mile or minutes per kilometer.
- Your heart rate. Note: Your heart rate can be displayed

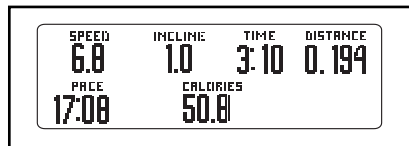

only while you use the handgrip pulse sensor or the optional chest pulse sensor. If you wish to see your heart rate for more than 40 seconds, select the display option shown above.

Note: Regardless of which display mode you select, the speed or incline setting will appear in the display for a few seconds each time you change the setting. In addition, your heart rate will appear in the display each time you use the handgrip pulse sensor or the optional chest pulse sensor (see step 7).

As you exercise, the workout intensity level bar will indicate the approximate intensity level of your exercise. For example, if eight of the indicators in the bar are lit, the bar shows that your intensity level is ideal for aerobic exercise.

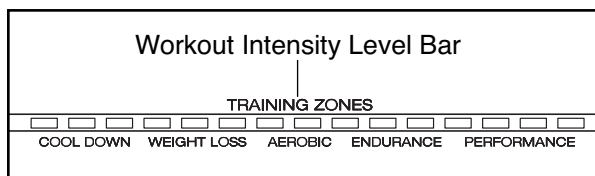

7. Measure your heart rate if desired.

If you hold the handgrip pulse sensor and wear the optional chest pulse sensor at the same time, the console will not display your heart rate accurately. See page 23 for information about the optional chest pulse sensor.

Before using the handgrip pulse sensor, remove the sheets of clear plastic from the metal contacts. In addition, make sure that your hands are clean.

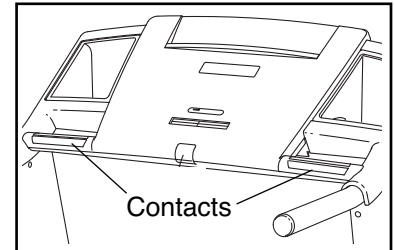

To measure your heart rate, **stand on the foot rails** and hold the metal contacts on the handrail—**avoid moving your hands**. When your pulse is detected, your heart rate will be shown. **For the most accurate heart rate reading, continue to hold the contacts for about 15 seconds.**

8. Turn on the fan if desired.

The fan features high and low speed settings. Press the Fan button repeatedly to select a fan speed or to turn off the fan. Note: If the fan is on when the walking belt is stopped, the fan will turn off automatically after a few minutes.

9. When you are finished exercising, remove the key from the console.

Step onto the foot rails, press the Stop button, and **adjust the incline of the treadmill to the lowest setting. The incline must be at the lowest setting when you fold the treadmill to the storage position or you may damage the treadmill.** Next, remove the key from the console and put it in a secure place.

When you are finished using the treadmill, switch the reset/off circuit breaker to the “off” position and unplug the power cord. **IMPORTANT: If you do not do this, the electrical components of the treadmill may wear prematurely.**

HOW TO USE A WEIGHT LOSS WORKOUT OR A PERFORMANCE WORKOUT

1. Insert the key into the console.

See HOW TO TURN ON THE POWER on page 14.

2. Personalize console settings if desired.

See HOW TO PERSONALIZE CONSOLE SETTINGS on page 20.

3. Select a weight loss workout or a performance workout.

To select one of the eight weight loss workouts or one of the eight performance workouts, press the Weight Loss Workouts button or the Performance Workouts button until the name of the desired preset workout appears in the display. Note: To return to a previous display, press the Back button.

When you select a weight loss workout or a performance workout, the display will



show the name, the maximum incline setting, the total time, and the maximum speed setting of the workout. In addition, a profile of the speed settings of the workout will appear in the display. If you select a weight loss workout, the display will also show the approximate number of calories you will burn.

Each preset workout is divided into one-minute segments. One speed setting and one incline setting are programmed for each segment. Note: The same speed and/or incline setting may be programmed for consecutive segments.

4. Press the Start button to start the workout.

A moment after you press the Start button, the treadmill will automatically adjust to the first speed and incline settings of the workout. Hold the handrails and begin walking.

During the program, the profile will show your progress. The flashing segment of the profile represents the current segment of the program. The

height of the flashing segment indicates the speed setting for the current segment. At the end of each segment, a series of tones will sound and the next segment of the profile will begin to flash and the speed and incline setting will appear in the display to alert you. The speed and incline will automatically adjust to the speed and incline settings programmed for the next segment.

The program will continue in this way until the last segment of the profile flashes in the display and the last segment ends. The walking belt will then slow to a stop.

If the speed or incline setting for the current segment is too high or too low, you can manually override the setting by pressing the speed and incline buttons. Every few times a speed button is pressed, an additional indicator will appear or disappear in the current segment column. **However, when the current segment of the program ends, the treadmill will automatically adjust to the speed and incline settings for the next segment.**

To stop the program at any time, press the Stop button. To restart the program, press the Start button or the Speed increase button. The walking belt will begin to move at 1 mph. When the next segment of the program begins, the treadmill will automatically adjust to the speed and incline settings for that segment.

5. Follow your progress with the display.

See step 6 on page 15.

Instead of displaying pace, the display will show your exercise intensity in METs. One MET is the amount of energy you use while resting.

6. Measure your heart rate if desired.

See step 7 on page 15.

7. Turn on the fan if desired.

See step 8 on page 15.

8. When you are finished exercising, remove the key from the console.

See step 9 on page 15.

HOW TO USE AN IFIT CARD

1. Insert the key into the console.

See HOW TO TURN ON THE POWER on page 14.

2. Insert an iFit card and select a workout.

To use an iFit workout, insert an iFit card into the iFit slot; make sure that the iFit card is oriented so the metal contacts are face-down and are inserted into the iFit slot.

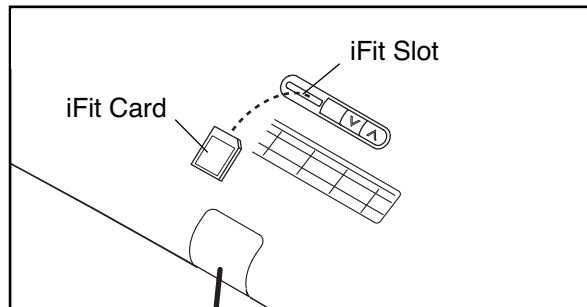

Next, select an iFit workout by pressing the iFit increase and decrease buttons next to the iFit slot. When an iFit workout is selected, the display will show the name of the workout, the maximum incline setting, the duration, and the maximum speed setting of the workout. In addition, a profile of the speed settings of the workout will appear in the display.

Each iFit workout is divided into several one-minute segments. One speed setting and one incline setting are programmed for each segment. Note: The same speed and/or incline setting may be programmed for consecutive segments.

3. Press the Start button to start the workout.

A moment after you press the Start button, the treadmill will automatically adjust to the first speed

and incline settings of the workout. Hold the handrails and begin walking.

During the workout, a personal trainer will guide you through the workout.

If the speed or incline setting for the current segment is too high or too low, you can manually override the setting by pressing the speed or incline buttons; **however, when the next segment begins, the treadmill will automatically adjust to the speed and incline settings for the next segment.**

To stop the workout at any time, press the Stop button. To restart the workout, press the Start button or the Speed increase button. The walking belt will begin to move at 1 mph. When the next segment of the workout begins, the treadmill will automatically adjust to the speed and incline settings for the next segment.

4. Follow your progress with the display.

See step 5 on page 16.

5. Turn on the fan if desired.

See step 8 on page 15.

6. When you are finished exercising, remove the key from the console.

See step 9 on page 15.

CAUTION: Always remove iFit cards from the iFit slot when you are not using them.

HOW TO USE THE IFIT COMPETITION TRAINING CENTER

1. Insert the key into the console.

See HOW TO TURN ON THE POWER on page 14.

2. Personalize console settings if desired.

See HOW TO PERSONALIZE CONSOLE SETTINGS on page 20.

3. Select the iFit Competition Training Center.

To select the iFit Competition Training Center, press the iFit Competition Training button. Use the navigation buttons to select a race against a group of four opponents or a race against one opponent.

If you choose to compete against a group, highlight the RACE A PACK option and then press the Enter button. Select a level of difficulty. Level one is the easiest level and level twelve is the hardest. The lower right corner of the display will show the average speed of the race. Press the Enter button. Select the distance of the race by pressing the navigation buttons and then press the Enter button. If you selected the choice incline mode, you can also select a profile of the incline settings of the race (see page 20).

If you choose to compete against one opponent, highlight the RACE A SINGLE OPPONENT option and then press the Enter button. Press the navigation buttons to view your opponent. For each the opponent, the screen will display a message from the opponent and the opponent's level of endurance, average speed, maximum speed, and level of spirit. Each opponent may appear more than once in different levels, or tiers, of difficulty. The least challenging opponent is in tier one and the most challenging opponent is in tier three. Select an opponent and press the Enter button. Then, press the navigation buttons to select the distance of the race and press the Enter button. If you selected the choice incline mode, you can also

select a profile of the incline settings of the race (see page 20).

After a few moments, READY, SET, GO will appear in the display and then the race will begin. Hold the handrails and begin walking.

Adjust the speed and incline of the treadmill as desired. Your opponents will adjust their speed and tactics based on the course and the situation.

The workout will continue until the race ends.

4. Follow your progress with the display.

The console offers several display options. The display option you select will determine which workout information is shown. Press the Display button repeatedly to select the desired display option.

As you walk or run on the treadmill, the display can show the following workout information:

- An animation of a runner labeled "U," which represents you. As you increase or decrease the speed of the walking belt, the runner will speed up or slow down.
- Animations of the other runners.
- A map of the course you are running will appear on the left side of the screen. The runners will be represented by squares on the map.
- Your number of seconds ahead of the other runners or behind the lead runner will appear below the map of the course. If you are behind the other runners, a negative number of seconds will appear.
- Your rank in the race will appear inside the map of the course.

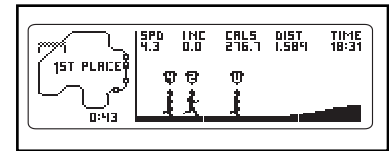

- The speed of the walking belt. Note: Press the Enter button to see your pace in minutes per kilometer or minutes per mile. Press the Enter button again to view the speed of the walking belt.
- The incline level of the treadmill.
- The approximate number of calories you have burned.
- The distance that you have walked or run.
- The elapsed time.
- Your heart rate. Note: Your heart rate can be displayed only while you use the handgrip pulse sensor or the optional chest pulse sensor (see page 15).
- A profile of the incline settings of the race will appear in the lower part of the screen.
- A status bar showing the distance you have travelled in the race and the distance you still have to travel.
- Your average speed.
- The rate at which your opponents recover their energy (rec). Your row in the rec column will display the approximate number of calories you have burned.

- The bank, or amount, of energy your opponents have left. As the amount of energy in a bank decreases, the speed of that opponent will decrease.
- The racing tactics your opponents are using. Your opponents will use different tactics in different situations. Consult a reputable source to learn more about these tactics.

5. Measure your heart rate if desired.

See step 7 on page 15.

To view your heart rate, select the display option shown at the right.

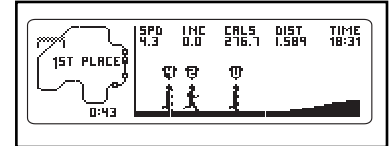

6. Turn on the fan if desired.

See step 8 on page 15.

7. When you are finished exercising, remove the key from the console.

See step 9 on page 15.

HOW TO PERSONALIZE CONSOLE SETTINGS

1. Insert the key into the console.

See HOW TO TURN ON THE POWER on page 14.

2. Select the settings mode.

To select the settings mode, press the iFit Competition Training button. Highlight the SETTINGS option and press the Enter button.

Note: To exit the settings mode at any time, press the Back button repeatedly until the manual mode is selected (see step 3 on page 14).

3. Enter user information.

The screen will display user name and user weight. To change user information,

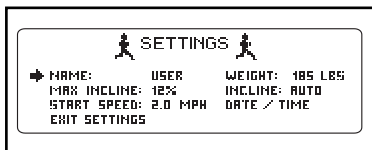

press the navigation buttons until an arrow appears next to the desired information. Then, press the Enter button. A flashing cursor will appear in a field in the display. To enter a number or letter above the cursor, press the navigation buttons. When you have finished entering the desired numbers or letters in the field, press the Enter button. Repeat this action to change all desired fields. When you have finished changing the fields, press the Enter button until the flashing cursor disappears.

4. Enter race settings.

The menu will also show the maximum incline, incline mode, and start speed for the competition

workout. If you change the maximum incline setting, the intensity of the entire workout will change. Choose the AUTO incline mode to use preset incline settings, the FLAT incline mode to use no incline settings, or the CHOICE incline mode to choose a profile of the incline settings at the beginning of a competition workout. If you change the start speed, the walking belt will begin moving at the selected speed whenever a competition workout begins.

5. Set the date and time.

Setting the date and time will allow the console to record your workout history accurately in the fitness journal.

To set the date and time, first move the arrow to the DATE / TIME option and press the Enter button. The date and time settings will then appear in the display.

Press the navigation buttons to move the cursor to the field you wish to change and press the Enter button. To enter a number or letter above the cursor, press the navigation buttons. When you have finished entering the desired numbers or letters in the field, press the Enter button. Repeat this action to change all the desired fields. Press the Back button to return to the settings mode.

6. Exit the settings mode.

When you are done changing the settings, highlight the EXIT SETTINGS option and press the Enter button.

HOW TO VIEW THE FITNESS JOURNAL

1. Insert the key into the console.

See HOW TO TURN ON THE POWER on page 14.

2. Select the fitness journal.

To select the fitness journal, press the iFit Fitness Journal button. The console will then load the stored journal information.

If you have not set the date and time, you may need to set the date and time before viewing the fitness journal. See step 5 on page 20 to set the date and time.

Note: As you view the fitness journal, press the Back button at any time to return to the previous menu or display.

The fitness journal can display the following exercise information:

- The total number of hours you have walked or run on the treadmill.
- The total distance you have walked or run on the treadmill.
- The total approximate number of calories you have burned.
- Your average walking or running speed.
- Your average walking or running pace in minutes per mile or minutes per kilometer.

3. View exercise information by year.

When you select the fitness journal, the year totals will appear in the display.

2008 TOTALS			
TIME	45.8	AVG. SPEED	3.8
DISTANCE	1267	AVG. PACE	15:49
CALORIES	22439.8		

To view exercise information for a different year, press the up and down Navigation buttons to

change the year. Note: The fitness journal can store information for 7 different years. You can only view a year for which information has been recorded.

4. View exercise information by month.

After a few seconds, the view month menu will appear in the display.

To view exercise information by month, press the up and down Navigation buttons to highlight the desired month in the right side of the display. Then, press the Enter button. The exercise information for the selected month will appear in the display.

5. View exercise information by week.

After a few seconds, the view week menu will appear in the display.

To view exercise information by week, press the up and down Navigation buttons to highlight the desired week in the right side of the display. Then, press the Enter button. The exercise information for the selected week will appear in the display.

6. View exercise information by day.

After a few seconds, the view day menu will appear in the display.

To view exercise information by day, press the left and right Navigation buttons until an arrow appears above the desired day in the right side of the display. Then, press the Enter button. The exercise information for the selected day will appear in the display.

7. Continue to view the fitness journal as desired.

Repeat steps 3 through 6 to view exercise information for the desired year, month, week, or day.

8. Exit the fitness journal.

Press the iFit Fitness Journal button to exit the fitness journal at any time.

THE INFORMATION MODE

The console features an information mode that allows you to select a unit of measurement for the console and turn on or turn off the display demo mode. You can also set the date and time.

To select the information mode, hold down the Stop button, insert the key into the console, and then release the Stop button. When the information mode is selected, the following information will appear in the display:

The display will show the selected unit of measurement. To change the unit of measurement, press the Speed increase button. To view distance in miles, select ENGLISH. To view distance in kilometers, select METRIC.

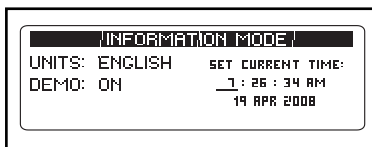

Note: The console features a display demo mode, designed to be used if the treadmill is displayed in a store. While the demo mode is turned on, the console will function normally when you plug in the power cord, switch the reset/off circuit breaker to the reset position, and insert the key into the console. However, when you remove the key, the displays will remain lit, although the buttons will not function. If the demo mode is turned on, the word "ON" will appear in display while the information mode is selected. To turn on or turn off the demo mode, press the Speed decrease button.

You can also set the date and time. To set the date and time, see step 5 on page 20.

To exit the information mode, remove the key from the console.

HOW TO USE THE STEREO SOUND SYSTEM

This product has been designed specifically to work with iPod and has been certified by the developer to meet Apple performance standards. To play music or audio books through the console's stereo speakers, you must connect your iPod, MP3 player, CD player, or other personal audio player to the console through the audio jack or through the Integrated Universal Dock for iPod.

To use the audio jack, locate the audio wire and plug it into the audio jack near the speakers. Then plug the audio wire into a jack on your MP3 player, CD player, or other personal audio player. **Make sure that the audio wire is fully plugged in.**

To use the Integrated Universal Dock for iPod, you need an iFit Universal iPod Connector. Plug one end into the Integrated Universal Dock for iPod near the speakers and the other end into your iPod. **Make sure that the iFit Universal iPod Connector is fully plugged in. To purchase an iFit Universal iPod Connector, call the telephone number on the front cover of this manual.**

Next, press the Play button on your iPod, MP3 player, CD player, or other personal audio player. Adjust the volume on your personal audio player or press the Volume increase and decrease buttons on the console.

If you are using a personal CD player and the CD skips, set the CD player on the floor or another flat surface and not on the console.

THE OPTIONAL CHEST PULSE SENSOR

An optional chest pulse sensor offers hands-free operation as it tracks your heart rate during your workouts.

To purchase the optional chest pulse sensor, call the telephone number on the front cover of this manual.

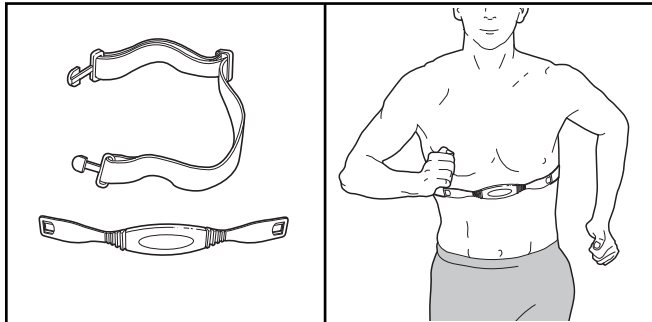

HOW TO ADJUST THE CUSHIONING SYSTEM

Remove the key from the console and unplug the power cord. The treadmill features a cushioning system that reduces the impact as you walk or run on the treadmill. To increase the firmness of the walking platform, step off the treadmill and slide the platform cushions toward the front of the treadmill. To decrease the firmness, step off the treadmill and slide the platform cushions toward the back of the treadmill. **Note: Make sure that both cushions are set at the same firmness level. The faster you run on the treadmill, or the more you weigh, the firmer the walking platform should be.**

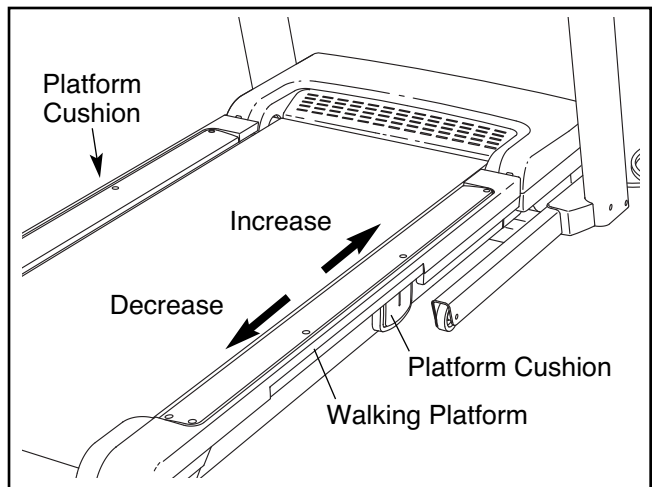

HOW TO FOLD AND MOVE THE TREADMILL

HOW TO FOLD THE TREADMILL FOR STORAGE

Before folding the treadmill, adjust the incline to the lowest position. If you do not do this, you may damage the treadmill when you fold it. Remove the key and unplug the power cord. **CAUTION:** You must be able to safely lift 45 lbs. (20 kg) to raise, lower, or move the treadmill.

1. Hold the metal frame firmly in the location shown by the arrow at the right. **CAUTION:** To decrease the possibility of injury, do not lift the frame by the plastic foot rails. Make sure to bend your legs and keep your back straight as you raise the frame. Raise the frame about halfway to the vertical position.
2. Raise the frame until the latch knob locks into the storage position. **Make sure that the latch knob is locked in the storage position.**

To protect the floor or carpet from damage, place a mat under the treadmill. Keep the treadmill out of direct sunlight. Do not leave the treadmill in the storage position in temperatures above 85° F (30° C).

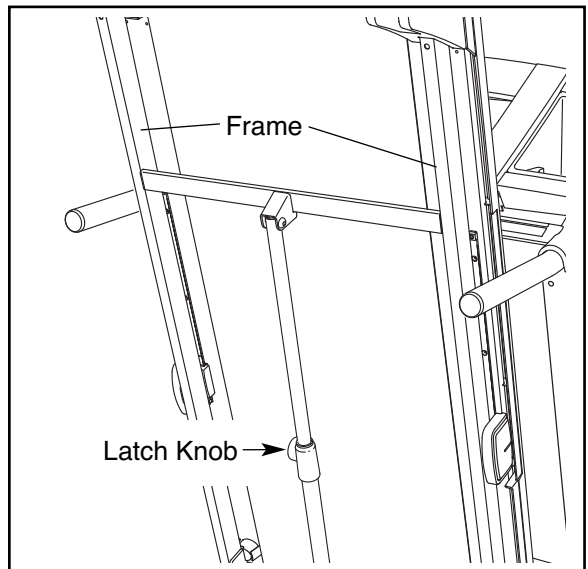
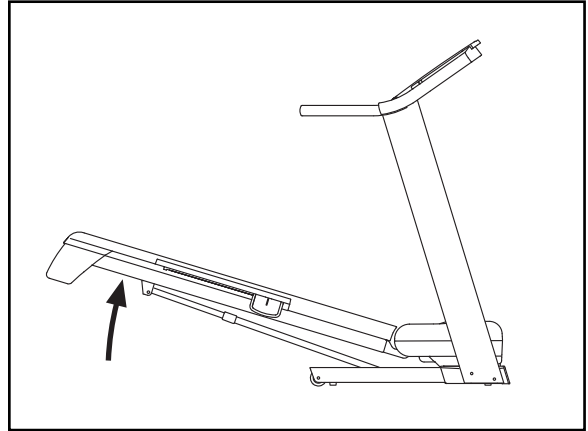

HOW TO MOVE THE TREADMILL

Before moving the treadmill, convert the treadmill to the storage position as described above. **Make sure that the latch knob is locked in the storage position.**

1. Hold a handrail and the frame and place one foot against one of the wheels.
2. Tilt the treadmill back until it rolls freely on the wheels. Carefully move the treadmill to the desired location. **Never move the treadmill without tipping it back. To reduce the risk of injury, use extreme caution while moving the treadmill. Do not attempt to move the treadmill over an uneven surface.**
3. Place one foot against a wheel, and carefully lower the treadmill until it is resting in the storage position.

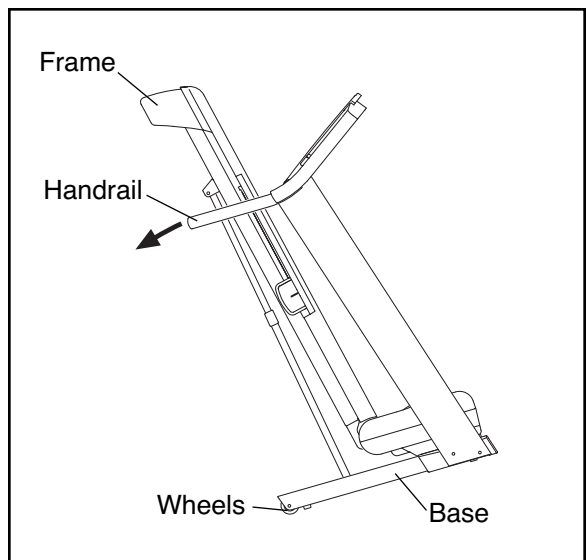

HOW TO LOWER THE TREADMILL FOR USE

1. Hold the upper end of the treadmill with your right hand. Pull the latch knob to the left and hold it. It may be necessary to push the frame forward as you pull the knob to the left. Pivot the frame downward and release the latch knob.

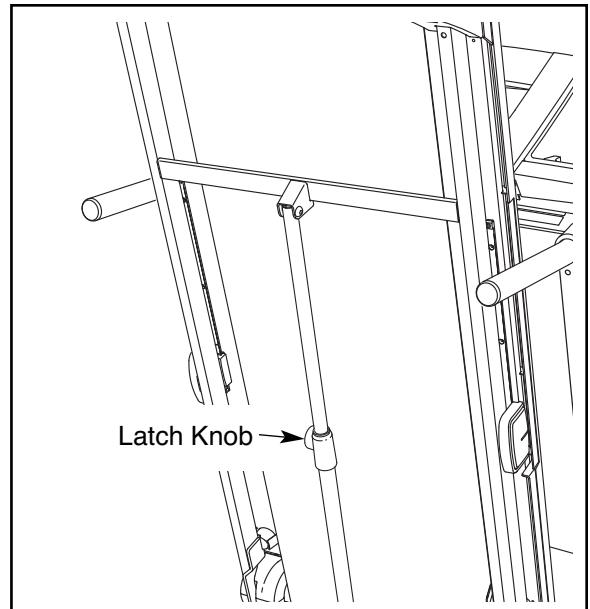

2. Hold the metal frame firmly with both hands and lower it to the floor. **CAUTION: Do not grip only the plastic foot rails or drop the frame to the floor. Bend your legs and keep your back straight.**

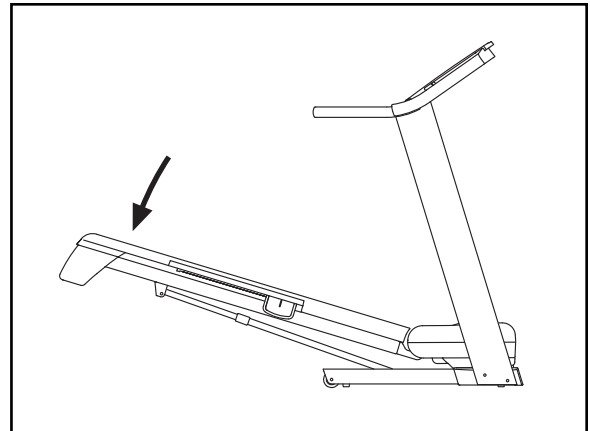

TROUBLESHOOTING

Most treadmill problems can be solved by following the steps below. Find the symptom that applies, and follow the steps listed. If further assistance is needed, please see the front cover of this manual.

PROBLEM: The power does not turn on

SOLUTION: a. Make sure that the power cord is plugged into a surge suppressor, and that the surge suppressor is plugged into a properly grounded outlet (see page 12). Use only a single-outlet surge suppressor that meets all of the specifications described on page 12. **IMPORTANT: The treadmill is not compatible with GFCI-equipped outlets.**

b. After the power cord has been plugged in, make sure that the key is inserted into the console.

c. Check the reset/off circuit breaker located on the treadmill frame near the power cord. If the switch protrudes as shown, the circuit breaker has tripped. To reset the circuit breaker, wait for five minutes and then press the switch back in.

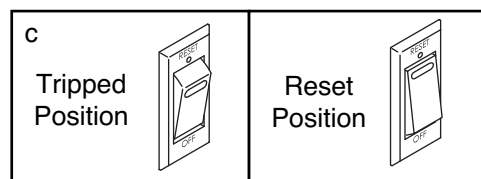

PROBLEM: The power turns off during use

SOLUTION: a. Check the reset/off circuit breaker (see the drawing above). If the circuit breaker has tripped, wait for five minutes and then press the switch back in.

b. Make sure that the power cord is plugged in. If the power cord is plugged in, unplug it, wait for five minutes, and then plug it back in.

c. Remove the key from the console. Reinsert the key into the console.

d. If the treadmill still will not run, please see the front cover of this manual.

PROBLEM: The console displays remain lit when you remove the key from the console

SOLUTION: a. The console features a display demo mode, designed to be used if the treadmill is displayed in a store. If the displays remain lit when you remove the key, the demo mode is turned on. To turn off the demo mode, hold down the Stop button for a few seconds. If the displays are still lit, see THE INFORMATION MODE on page 22 to turn off the demo mode.

PROBLEM: The displays of the console do not function properly

SOLUTION: a. Remove the key from the console and **UNPLUG THE POWER CORD**. With the help of a second person, carefully tip down the Uprights (74, 78). There may be two #8 x 2" Screws (105) in the bottom of the Belly Pan (73). If there are, remove them. Note: A Phillips screwdriver with a shaft at least 5 in. (13 cm) long is required. Raise the Uprights to a vertical position.

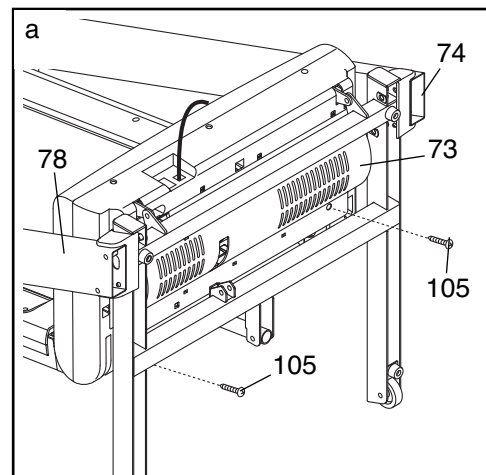

Remove the three #8 x 3/4" Screws (1) and carefully pivot the Hood (61) off.

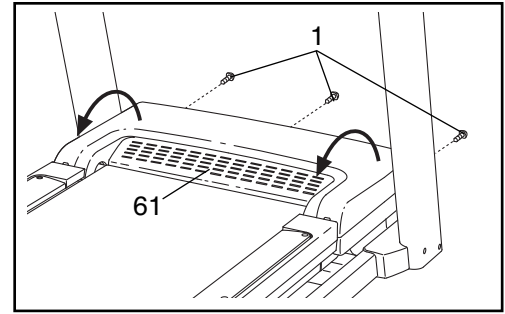

Locate the Reed Switch (71) and the Magnet (50) on the left side of the Pulley (51). Turn the Pulley until the Magnet is aligned with the Reed Switch. **Make sure that the gap between the Magnet and the Reed Switch is about 1/8 in. (3 mm).** If necessary, loosen the 3/4" Reed Switch Screw (15), move the Reed Switch slightly, and then retighten the Screw. Reattach the Hood (not shown). If necessary, tip down the Uprights (not shown), reattach the #8 x 2" Screws (not shown), and raise the Uprights. Run the treadmill for a few minutes to check for a correct speed reading.

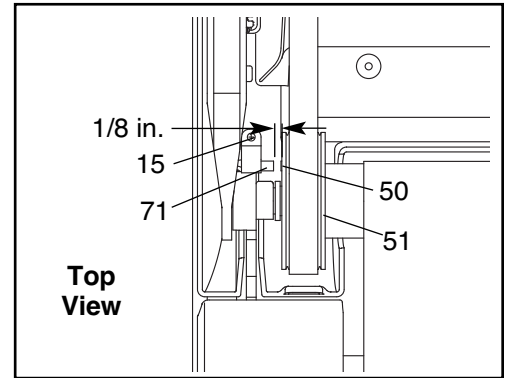

PROBLEM: The incline of the treadmill does not change correctly

SOLUTION: a. Hold down the Stop button and the Speed increase button, insert the key into the console, and then release the Stop button and the Speed increase button. Press the Incline increase or decrease button. The treadmill will automatically rise to the maximum incline level and then return to the minimum level. This will recalibrate the incline system. If the incline does not calibrate, press the Stop button, and then press the Incline increase or decrease button again. When the incline is calibrated, remove the key from the console.

PROBLEM: The walking belt slows when walked on

SOLUTION: a. Use only a single-outlet surge suppressor that meets all of the specifications described on page 12.

b. If the walking belt is overtightened, treadmill performance may decrease and the walking belt may become damaged. Remove the key and **UNPLUG THE POWER CORD**. Using the hex key, turn both rear roller bolts counterclockwise, 1/4 of a turn. When the walking belt is properly tightened, you should be able to lift each edge of the walking belt 2 to 3 in. (5 to 7 cm) off the walking platform. Be careful to keep the walking belt centered. Then, plug in the power cord, insert the key, and run the treadmill for a few minutes. Repeat until the walking belt is properly tightened.

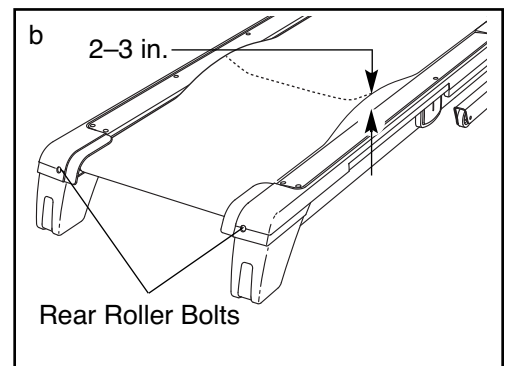

c. If the walking belt still slows when walked on, see the front cover of this manual.

PROBLEM: The walking belt is off-center or slips when walked on

SOLUTION: a. **If the walking belt is off-center**, first remove the key and **UNPLUG THE POWER CORD**. **If the walking belt has shifted to the left**, use the hex key to turn the left rear roller bolt clockwise 1/2 of a turn; **if the walking belt has shifted to the right**, turn the bolt counterclockwise 1/2 of a turn. Be careful not to overtighten the walking belt. Then, plug in the power cord, insert the key, and run the treadmill for a few minutes. Repeat until the walking belt is centered.

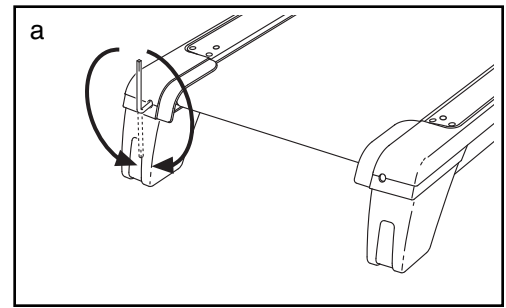

b. **If the walking belt slips when walked on**, first remove the key and **UNPLUG THE POWER CORD**. Using the hex key, turn both rear roller bolts clockwise, 1/4 of a turn. When the walking belt is correctly tightened, you should be able to lift each edge of the walking belt 2 to 3 in. (5 to 7 cm) off the walking platform. Be careful to keep the walking belt centered. Then, plug in the power cord, insert the key, and carefully walk on the treadmill for a few minutes. Repeat until the walking belt is properly tightened.

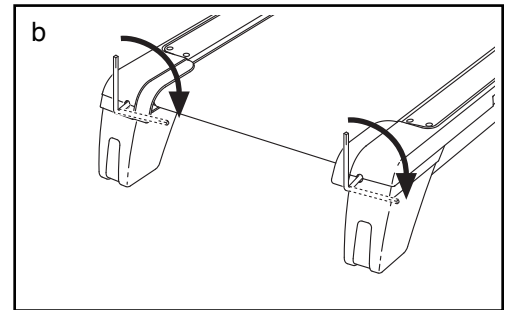

EXERCISE GUIDELINES

⚠️ WARNING: Before beginning this or any exercise program, consult your physician. This is especially important for persons over the age of 35 or persons with pre-existing health problems.

The pulse sensor is not a medical device. Various factors may affect the accuracy of heart rate readings. The pulse sensor is intended only as an exercise aid in determining heart rate trends in general.

These guidelines will help you to plan your exercise program. For detailed exercise information, obtain a reputable book or consult your physician. Remember, proper nutrition and adequate rest are essential for successful results.

EXERCISE INTENSITY

Whether your goal is to burn fat or to strengthen your cardiovascular system, exercising at the proper intensity is the key to achieving results. You can use your heart rate as a guide to find the proper intensity level. The chart below shows recommended heart rates for fat burning and aerobic exercise.

165	155	145	140	130	125	115	♥
145	138	130	125	118	110	103	♥
125	120	115	110	105	95	90	♥
<hr/>							
20	30	40	50	60	70	80	

To find the proper intensity level, find your age at the bottom of the chart (ages are rounded off to the nearest ten years). The three numbers listed above your age define your “training zone.” The lowest number is the heart rate for fat burning, the middle number is the heart rate for maximum fat burning, and the highest number is the heart rate for aerobic exercise.

Burning Fat—To burn fat effectively, you must exercise at a low intensity level for a sustained period of time. During the first few minutes of exercise, your body uses *carbohydrate calories* for energy. Only after the first few minutes of exercise does your body begin to use stored *fat calories* for energy. If your goal is to burn fat, adjust the intensity of your exercise until your heart rate is near the lowest number in your training zone. For maximum fat burning, exercise with your heart rate near the middle number in your training zone.

Aerobic Exercise—If your goal is to strengthen your cardiovascular system, you must perform aerobic exercise, which is activity that requires large amounts of oxygen for prolonged periods of time. For aerobic exercise, adjust the intensity of your exercise until your heart rate is near the highest number in your training zone.

WORKOUT GUIDELINES

Warming up—Start with 5 to 10 minutes of stretching and light exercise. A warm-up increases your body temperature, heart rate, and circulation in preparation for exercise.

Training Zone Exercise—Exercise for 20 to 30 minutes with your heart rate in your training zone. (During the first few weeks of your exercise program, do not keep your heart rate in your training zone for longer than 20 minutes.) Breathe regularly and deeply as you exercise—never hold your breath.

Cooling down—Finish with 5 to 10 minutes of stretching. Stretching increases the flexibility of your muscles and helps to prevent post-exercise problems.

EXERCISE FREQUENCY

To maintain or improve your condition, complete three workouts each week, with at least one day of rest between workouts. After a few months of regular exercise, you may complete up to five workouts each week, if desired. Remember, the key to success is to make exercise a regular and enjoyable part of your everyday life.

PART LIST—Model No. PFTL99908.0

R0708A

To locate the parts listed below, see the EXPLODED DRAWING near the end of this manual.

Key No.	Qty.	Description	Key No.	Qty.	Description
1	25	#8 x 3/4" Screw	51	1	Front Roller/Pulley
2	4	#8 x 1" Tek Screw	52	3	15 1/2" Wire Tie
3	1	Hex Key	53	1	Storage Latch
4	6	3/8" x 2" Bolt	54	1	Latch Knob
5	2	1/4" x 1 1/4" Bolt	55	1	Right Foot Rail
6	4	3/8" x 4 1/2" Bolt	56	1	Frame
7	6	5/16" x 1 1/2" Bolt	57	2	Rear Roller Bracket
8	8	3/8" Nut	58	1	Rear Roller
9	4	3/8" Star Washer	59	1	Left Rear Foot
10	6	5/16" Star Washer	60	1	Right Rear Foot
11	5	#8 x 3/4" Tek Screw	61	1	Hood
12	4	#8 x 1/2" Screw	62	1	Drive Belt
13	2	Base Foot Spacer	63	2	#8 x 1" Screw
14	1	Latch Bracket	64	1	Motor
15	1	3/4" Reed Switch Screw	65	1	Lift Frame
16	10	#8 x 3/4" Screw	66	3	Wire Tie
17	2	1/4" x 1 1/4" Bolt	67	1	Controller Ground Wire
18	2	5/16" x 4 1/4" Bolt	68	1	Power Cord
19	2	3/8" x 1 1/4" Bolt	69	1	Power Cord Grommet
20	2	Rear Roller Bolt	70	1	Controller
21	1	3/8" x 1 3/4" Bolt	71	1	Reed Switch
22	1	3/8" x 1 1/2" Bolt	72	1	Reed Switch Clip
23	2	3/8" x 1" Bolt	73	1	Belly Pan
24	8	1/2" Ground Screw	74	1	Left Upright
25	10	#12 x 1 1/4" Screw	75	1	Incline Motor
26	2	Motor Bolt	76	1	Left Upright Spacer
27	2	Cushion Stop	77	4	Bolt Spacer
28	1	Reset/Off Circuit Breaker	78	1	Right Upright
29	10	Belt Guide Screw/Hood Accent Screw	79	1	Right Upright Spacer
30	2	1/4" x 3/4" Flat Washer	80	1	Frame/Roller Ground Wire
31	2	1/4" Lock Washer	81	4	Base Foot
32	2	3/8" Incline Motor Nut	82	2	Caution Decal
33	2	1/4" Star Washer	83	1	Base
34	4	#8 x 1 3/4" Screw	84	2	Wheel
35	1	Audio Wire	85	2	Releasable Tie
36	2	5/16" Flange Nut	86	9	8" Tie
37	3	Hood Clip	87	1	Access Door
38	1	Upright Wire	88	2	Cage Nut
39	1	Lift Frame Ground Wire	89	1	Console
40	2	Front Isolator	90	1	Hood Accent
41	1	Left Foot Rail	91	1	Console Base
42	1	Warning Decal	92	1	Plastic Tie
43	2	Walking Platform Cushion	93	1	Incline Wire
44	1	Walking Platform	94	1	Handrail Crossbar
45	1	Walking Belt	95	1	Right Handrail
46	2	Belt Guide	96	1	Left Handrail
47	2	Cushion Track	97	1	Right Accessory Tray
48	2	Frame Spacer	98	4	Handrail Cap
49	3	Front Roller Spacer	99	1	Left Accessory Tray
50	1	Magnet	100	1	Key/Clip

Key No.	Qty.	Description
101	1	Console Ground Wire
102	2	#8 x 2" Screw
103	1	5/32" Hex Key
104	1	Lift Motor Spacer
*	–	4" Black Wire, M/F

Key No.	Qty.	Description
*	–	4" White Wire, M/F
*	–	User's Manual

*These parts are not illustrated.
 Specifications are subject to change without notice.

EXPLODED DRAWING A—Model No. PFTL99908.0

R0708A

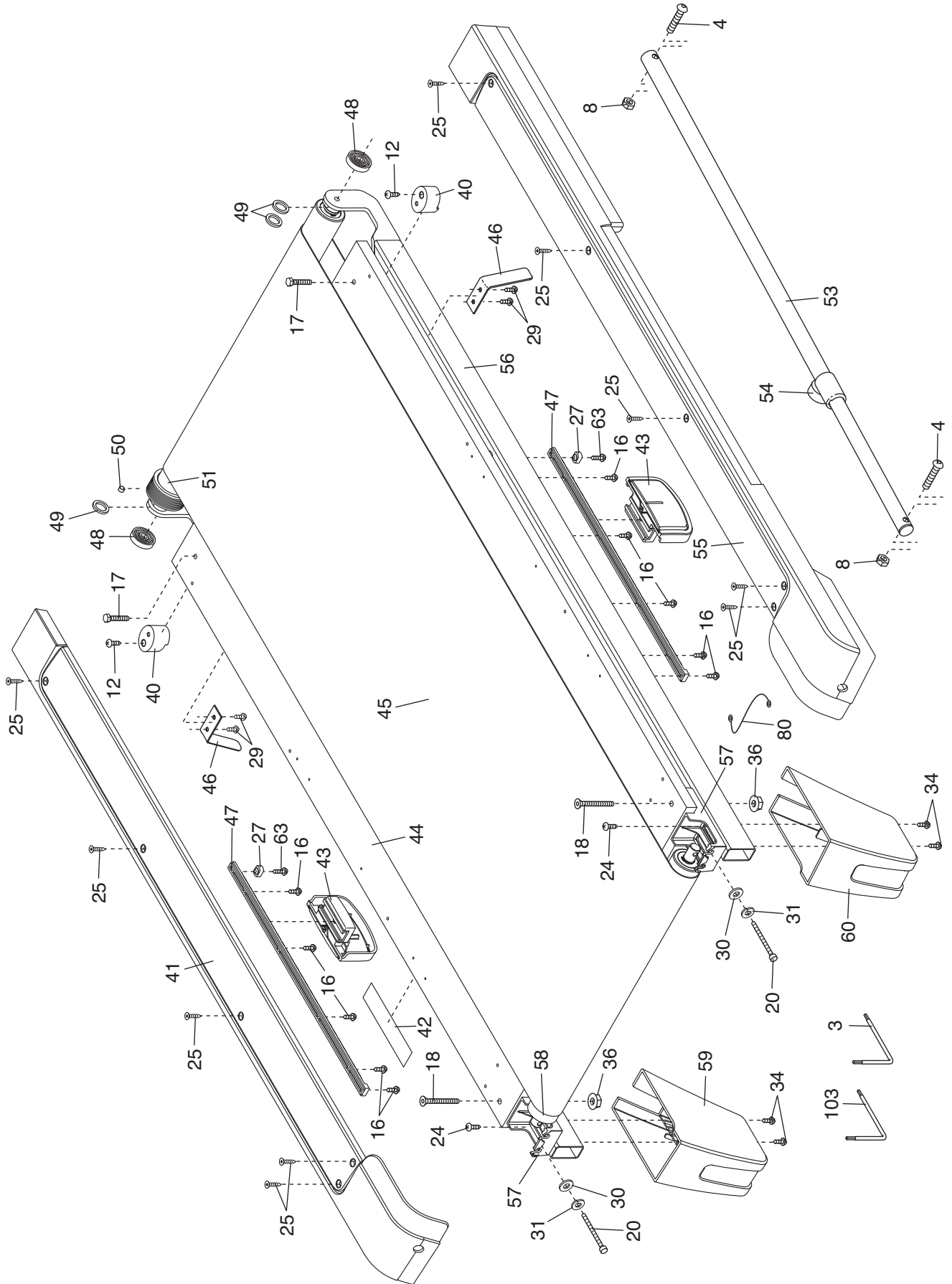

EXPLODED DRAWING B—Model No. PFTL99908.0

R0708A

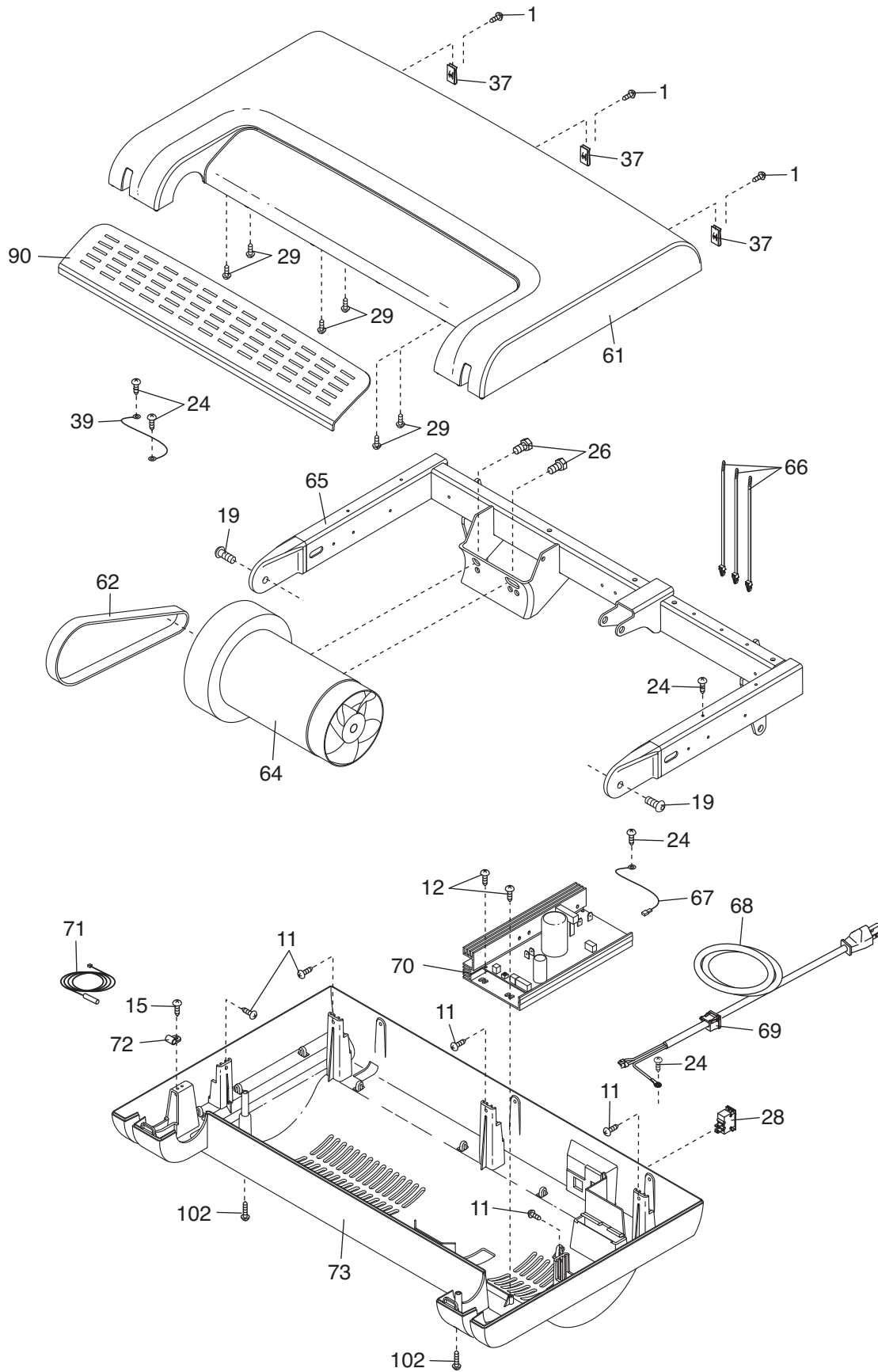

EXPLODED DRAWING D—Model No. PFTL99908.0

R0708A

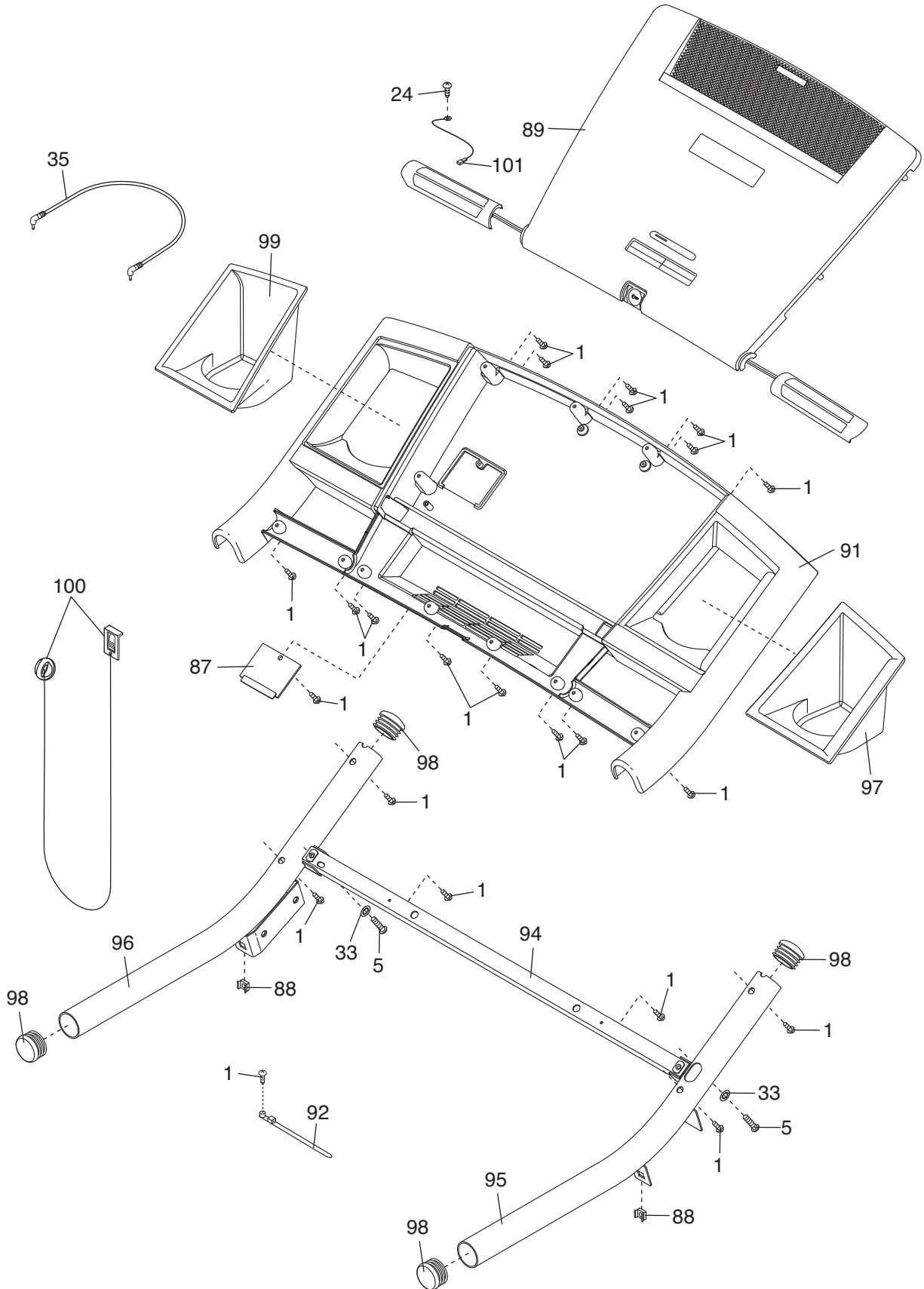

ORDERING REPLACEMENT PARTS

To order replacement parts, please see the front cover of this manual. To help us assist you, be prepared to provide the following information when contacting us:

- the model number and serial number of the product (see the front cover of this manual)
- the name of the product (see the front cover of this manual)
- the key number and description of the replacement part(s) (see the PART LIST and the EXPLODED DRAWING near the end of this manual)

LIMITED WARRANTY

ICON Health & Fitness, Inc. (ICON) warrants this product to be free from defects in workmanship and material, under normal use and service conditions. The frame and drive motor are warranted for a lifetime. Parts and labor are warranted for one (1) year after the date of purchase.

This warranty extends only to the original purchaser. ICON's obligation under this warranty is limited to repairing or replacing, at ICON's option, the product through one of its authorized service centers. All repairs for which warranty claims are made must be preauthorized by ICON. If the product is shipped to a service center, freight charges to and from the service center will be the customer's responsibility. For replacement parts shipped while the product is under warranty, the customer will be responsible for a minimal handling charge. For in-home service, the customer will be responsible for a minimal trip charge. This warranty does not extend to any damage to a product caused by or attributable to freight damage, abuse, misuse, improper or abnormal usage, or repairs not provided by an ICON authorized service center; products used for commercial or rental purposes; or products used as store display models. No other warranty beyond that specifically set forth above is authorized by ICON.

ICON is not responsible or liable for indirect, special, or consequential damages arising out of or in connection with the use or performance of the product; damages with respect to any economic loss, loss of property, loss of revenues or profits, loss of enjoyment or use, or costs of removal or installation; or other consequential damages of whatsoever nature. Some states do not allow the exclusion or limitation of incidental or consequential damages. Accordingly, the above limitation may not apply to you.

The warranty extended hereunder is in lieu of any and all other warranties, and any implied warranties of merchantability or fitness for a particular purpose are limited in their scope and duration to the terms set forth herein. Some states do not allow limitations on how long an implied warranty lasts. Accordingly, the above limitation may not apply to you.

This warranty gives you specific legal rights. You may also have other rights that vary from state to state.

ICON Health & Fitness, Inc., 1500 S. 1000 W., Logan, UT 84321-9813